



# Archaeological Desk-Based Assessment in advance of the Proposed Development at Aylesford Lakes, Aylesford, Kent

October 2017

Archaeological Desk-Based Assessment in advance  
of the Proposed Development at Aylesford Lakes,  
Aylesford, Kent ME20 7DX

NGR: 573274 159312



Report for Aylesford Heritage Ltd

Date of Report: 17/10/2017

**SWAT. ARCHAEOLOGY**

Swale and Thames Archaeological Survey Company

School Farm Oast, Graveney Road

Faversham, Kent

ME13 8UP

Tel; 01795 532548 or 07885 700 112

[www.swatarchaeology.co.uk](http://www.swatarchaeology.co.uk)

## Contents

<i>Appendix 1 Archaeological Sites</i> .....	30
<i>List of Plates</i> .....	iii
<i>List of Figures</i> .....	iii
1. SUMMARY.....	5
2. INTRODUCTION.....	6
2.1 Geology and Topography.....	8
2.2 Planning Background.....	9
2.2.1 Conserving and Enhancing the Historic Environment.....	9
2.3 The Proposed Development.....	11
2.4 Project Constraints.....	11
3. AIMS AND OBJECTIVES.....	11
3.1 Introduction.....	12
3.2 Desktop Study – Institute For Archaeologists (revised 2011).....	12
4. METHODOLOGY.....	12
4.1 Desk-Based Assessment.....	12
4.1.1 Archaeological databases.....	12
4.1.2 Historical documents.....	12
4.1.3 Cartographic and pictorial documents.....	13
4.1.4 Aerial photographs.....	14
4.1.5 Geotechnical information.....	15
4.1.6 Secondary and statutory resources.....	15
5. ARCHAEOLOGICAL AND HISTORICAL DEVELOPMENT.....	15
5.1 Introduction.....	15
5.2 History of the Site.....	16
5.3 Archaeological and Historical Development.....	17
5.4 Scheduled Monuments, Listed Buildings Historic Parks & Gardens and Conservation Areas.....	17

5.5	Walkover Survey.....	18
6.	ARCHAEOLOGICAL POTENTIAL.....	18
6.1	Palaeolithic, Mesolithic, Neolithic and Bronze Age.....	18
6.2	Roman-British.....	20
6.3	Iron Age.....	20
6.4	Anglo-Saxon.....	22
6.5	Medieval.....	22
6.6	Post-Medieval and Modern.....	22
6.7	Summary of Potential.....	27
7.	IMPACT ASSESSMENT.....	27
7.1	Introduction.....	27
7.2	Existing Impacts.....	28
7.3	Proposed Impacts.....	29
7.3.1	The general development of the site.....	29
7.4	Proposed mitigation for the impact of the construction process.....	29
8.	MITIGATION.....	29
9.	OTHER CONSIDERATIONS.....	29
9.1	Archive.....	30
9.2	Reliability/limitations of sources.....	30
9.3	Copyright.....	30
10.	REFERENCES & BIBLIOGRAPHY.....	31



## List of Plates

- Plate 1. Google Earth 1940
- Plate 2. Google Earth 1960
- Plate 3. Google Earth view 1990
- Plate 4. Google Earth view 2007
- Plate 5. Google Earth view 2013
- Plate 6. Aerial photo 2015
- Plate 7. Landscape PDA
- Plate 8. Landscape PDA
- Plate 9. Aerial photograph of cropmarks
- Plate 10. Aerial photograph of cropmarks
- Plate 11. Aerial photograph of cropmarks

## List of Figures

- Fig.1 Site location map 1:20000
- Fig.2 Digital Surface Model
- Fig.3 Map of 1596
- Fig.4 Map of 1769
- Fig.5 Historic mapping OS 1:2500 1769
- Fig.6 Historic mapping OS 1:2500 1869
- Fig.7 Historic mapping OS 1:2500 1896
- Fig.8 Historic mapping OS 1:2000 1907
- Fig.9 Historic mapping OS 1:2500 1931
- Fig.10 Historic mapping OS 1:2000 1948
- Fig.10 Historic mapping OS 1:2000 1958
- Fig.11 Historic mapping OS 1:2000 1961

## Archaeological Desk-Based Assessment in Advance of the Proposed Development at Aylesford Lakes, Aylesford. Kent

NGR: 573274 159312

### 1 SUMMARY

*Swale & Thames Survey Company (SWAT Archaeology) has been commissioned to carry out an archaeological desk-based assessment in advance of the proposed residential development at Aylesford Lakes, Aylesford, Kent (Figures 1-2) as part of the planning application submitted by Aylesford Heritage Ltd.*

*This Desk Based Assessment examines the wide variety of archaeological data held by Kent County Council and other sources.*

*Based on this data the potential for archaeological sites either on or in the near vicinity of the Proposed Development Area (PDA) can be summarised as:*

- *Prehistoric: High*
- *Iron Age: Moderate*
- *Romano-British: High*
- *Anglo-Saxon: Low*
- *Medieval: Low*
- *Post-medieval: High*
- *Modern: High*

*The Desk Based Assessment concludes that:*

- *The site has **high** potential for any archaeological discoveries.*

*The PDA is an area of agricultural fields not previously quarried adjacent to a group of quarries that now form lakes located at Tottington Farm, north west of Aylesford village. Aylesford is a civil parish situated on the River Medway, 4 miles northwest of*

*Maidstone, in the county of Kent and the southeast of England. The area is characterised as fields predominantly bounded by tracks, roads and other rights of way and active and disused gravel and clay workings. The sand and gravel quarries cover an area of c.5000 sqm and have been in existence for over 100 years beginning to the northeast of the church. In the early years they were known as 'Wagon's Pit' but were later referred to as 'Aylesford gravel pit'. They are a good source of gravel, flint, lower greensand chert, ragstone and sandstone.*

*Agricultural fields bound all three quarries to the north; the Rochester Road is located just east of the east quarry, the High Street and an area of low-density residential development are found just south and beyond this the River Medway. Industrial development bounds the west lake to the southwest (Figures 1-2).*

## **2 INTRODUCTION**

2.1 SWAT Archaeology has been commissioned by Aylesford Heritage Ltd to carry out an Archaeological Desk-Based Assessment to supplement a planning application for the proposed residential development at Aylesford Lakes, Aylesford in Kent (Figures 1-2). The report has accessed various sources of information to identify any known heritage assets, which may be located within the vicinity of the Proposed Development Area. The PDA is centered on National Grid Reference: NGR 573274 159312.

2.2 Archaeological investigations, both recent and historic have been studied and the information from these investigations has been incorporated in to the assessment.

This report is a desk-based appraisal from known cartographic, photographic and archaeological sources and is a research led statement on the archaeological potential of the proposed development.

2.3 It may be that intrusive investigations, such as a Geophysical Survey and/or an Archaeological Evaluation, with machine cut trial trenching, may be requested by the Local Planning Authority (LPA) as a Planning Condition.

2.4 The site falls within the Medway Valley Palaeolithic Project zone KT52. The Medway Valley is home to archaeological sites that date from the Neolithic period and particularly to a large number of Roman sites in close proximity to the Rochester Road. In 1861, local Maidstone geologist W. Benstead noted that the quarries were a potential source of Palaeolithic implements and the following year the discovery of mammoth remains were recorded in 'The Geologist'. Despite reports of mammoth, rhinoceros and horse remains in 1865, only woolly rhinoceros and straight-tusked elephant were recorded during an excursion to the quarry in 1869. Numerous teeth, remains of mammoth and a large mammoth tusk measuring 10ft were collected.

2.5 In 1883 workmen, accompanied by Benjamin Harrison, found Palaeolithic implements, specifically two pointed hand axes, although later reports claimed that these finds lacked provenance. F J Bennett claimed in a report dated 1904, to have found some 500 worked flints over a period of 10 years. A report in 1923 listed Lion, Usus, Bison, Irish elk, Red Deer, Horse, Rhinoceros, Straight-Tusked Elephant, Mammoth and Wild Boar among the mammalian remains and artefacts of the Chellean, Acheulian I, Acheulian II and the Mousterian type. There was little stratigraphical control and deposits were referred to as the 'low' or '25ft' terrace of the Medway, however, later reports have attributed them to the '2<sup>nd</sup>', 'Middle', 'Taplow' or "50ft' Terrace.

2.6 A geophysical survey (EKE5353/8464) was carried out in 1998 by The Clark Laboratory of the Museum of London Archaeology prompted by cropmark evidence of an enclosure and a Belgic cremation cemetery to the south. The survey confirmed the presence of the cropmark enclosure and an additional smaller enclosure (Appendix 1).

2.7 Following the geophysical survey, Canterbury Archaeological Trust carried out an evaluation of 7 trenches in 1999 (EKE5759). Trenches 1 & 3 contained no archaeological features or deposits. The remaining trenches contained pits and

ditches, dating from the late Iron Age period (mid first century), to the early Roman period (late first century) and some features were thought to be of prehistoric origin. The presence of 'opus signinum', ridge tile and domestic waste suggested settlement and occupation (trench 5) and many of the ditches were enclosure ditches that had been re-cut suggesting continued use over a period of time; Rowe Place Farm, Eccles, 2km northwest, is the site of the major villa estate of the Medway valley (Appendix 2).

2.8 An excavation was carried out at Parish Field in 1986 uncovering a Belgic Cemetery (EKE3950).

2.9 The University of Southampton opened a test pit (EKE14367) at Aylesford quarry, although no artefacts were recovered, a sequence of deposits was clarified. They carried out several desk-based assessments to review the collections of artefacts held at museums.

2.10 In 2006 Kent Underground Research Group carried out a survey of a sand mine at 32 Mount Pleasant and uncovered a 7m shaft and chamber (EKE13132).

2.11 Excavations in 1994 (EKE5098) and three watching briefs carried out at St Peter's School in 2005, 2008 and 2011 uncovered the remains of the 18<sup>th</sup> century vicarage and 3-chambered cellar dating to 1750 (EKE11542/10636/9002) and a watching brief (EKE10037) at the Old Mill House in 2004 discovered further details relating to the development of the mill house (HER Figures 11-17).

## **2.12 Geology and Topography**

The Geological Survey of Great Britain (1:50,000) shows that the PDA is set on Bedrock Geology of Folkestone formation – Sandstone and gault formation – Mudstone, sedimentary bedrock formed approximately 100 to 125 million years ago in the Cretaceous period in a local environment previously dominated by shallow seas. These rocks were formed in shallow seas with mainly siliciclastic sediments



(comprising of fragments or clasts of silicate minerals) deposited as mud, silt, sand and gravel.

Superficial deposits of River Terrace Deposits (undifferentiated) – Clay and Silt Gravel and River terrace Deposits 2 – Sand and Gravel, formed up to 3 million years ago in the Quaternary Period, in a local environment previously dominated by rivers depositing mainly sand and gravel detrital material in channels to form river terrace deposits, with fine silt and clay from overbank floods forming floodplain alluvium, and some bogs depositing peat; includes estuarine and coastal plain deposits mapped as alluvium.

### **2.13 Planning Background**

The National Planning Policy Framework (March 2012)

Policy 12 is the relevant policy for the historic environment:

#### **2.2.1 Conserving and Enhancing the Historic Environment**

Local planning authorities should set out in their Local Plan a positive strategy for the conservation and enjoyment of the historic environment, including heritage assets most at risk through neglect, decay or other threats. In doing so, they should recognise that heritage assets are an irreplaceable resource and conserve them in a manner appropriate to their significance. In developing this strategy, local planning authorities should take into account:

- the desirability of sustaining and enhancing the significance of heritage assets and putting them to viable uses consistent with their conservation;
- the wider social, cultural, economic and environmental benefits that conservation of the historic environment can bring;
- the desirability of new development making a positive contribution to local character and distinctiveness; and
- opportunities to draw on the contribution made by the historic environment to the character of a place.

2.2.2 In determining applications, local planning authorities should require an applicant to describe the significance of any heritage assets affected, including any contribution made by their setting. The level of detail should be proportionate to the assets' importance and no more than is sufficient to understand the potential impact of the proposal on their significance. As a minimum the relevant historic environment record should have been consulted and the heritage assets assessed using appropriate expertise where necessary. Where a site on which development is proposed includes or has the potential to include heritage assets with archaeological interest, local planning authorities should require developers to submit an appropriate desk-based assessment and, where necessary, a field evaluation (NPPF 2012).

#### **2.14 Local Policies**

Tonbridge and Malling Borough Council have planning policies on:

Heritage Assets Nov 2016

Listed buildings Nov 2016

Conservation Areas Nov 2016

#### **2.15 Regional Policies**

The South-East Research Framework (SERF) is on-going with groups of researchers producing a Resource Assessment, which will identify research questions and topics in order to form a Research Agenda for the future.

2.16 This Archaeological Desk-Based Assessment has been prepared in accordance with the guidance in the National Planning Policy Framework and the Good Practise Advice notes 1, 2 and 3, which now supersede the PPS 5 Practise Guide, which has been withdrawn by the Government. The Good Practise Advice notes emphasises the need for assessments of the significance of any heritage assets, which are likely to be changed, so the assessment can inform the decision process. Significance is defined in the NPPF Guidance in the Glossary as “the value of the heritage asset to this and future generations because of its heritage interest. That interest may be archaeological, architectural, artistic, or historical. Significance derives not only from

a heritage asset's physical presence, but also it's setting". The setting of the heritage asset is also clarified in the Glossary as "the surroundings in which a heritage asset is experienced. Its extent is not fixed and may change as the asset and its surroundings evolve".

2.17 This Desk-Based Assessment therefore forms the initial stage of the archaeological investigation and is intended to inform and assist in decisions regarding archaeological mitigation for the proposed development and associated planning applications.

### **2.18 The Proposed Development**

The proposed development will comprise of a planning application for residential and other development with associated parking, access roads and landscaping.

### **2.19 Project Constraints**

No project constraints were encountered during the data collection for this assessment.

## **3 AIMS AND OBJECTIVES**

**3.1** The Desk-Based Assessment was commissioned by Aylesford Heritage Ltd in order to supplement a planning application for the proposed residential development at Aylesford lakes, Aylesford in Kent, and to establish the potential for archaeological features and deposits.

### **3.2 Desktop Study – Institute for Archaeologists (revised 2011)**

This desktop study has been produced in line with archaeological standards, as defined by the Institute for Archaeologists (2014). A desktop, or desk-based assessment, is defined as being:

*"a programme of study of the historic environment within a specified area or site on land, the inter-tidal zone or underwater that addresses agreed research and/or*

*conservation objectives. It consists of an analysis of existing written, graphic, photographic and electronic information in order to identify the likely heritage assets, their interests and significance and the character of the study area, including appropriate consideration of the settings of heritage assets and, in England, the nature, extent and quality of the known or potential archaeological, historic, architectural and artistic interest. Significance is to be judged in a local, regional, national or international context as appropriate". (CiFA 2014)*

## **4 METHODOLOGY**

### **4.1 Desk-Based Assessment**

#### *4.1.1 Archaeological Databases*

The local Historic Environment Record (HER) held at Kent County Council provides an accurate insight into catalogued sites and finds within both the proposed development area (PDA) and the surrounding environs of Aylesford.

The Archaeology Data Service Online Catalogue (ADS) was also used. The search was carried out within a 500m radius of the proposed development site and relevant HER data is included in the report. The Portable Antiquities Scheme Database (PAS) was also searched as an additional source as the information contained within is not always transferred to the local HER.

#### *4.1.2 Historical Documents*

Historical documents, such as charters, registers, wills and deeds etc., were considered not relevant to this specific study.

#### *4.1.3 Cartographic and Pictorial Documents*

A cartographic and pictorial document search was undertaken during this assessment. Research was carried out using resources offered by Kent County Council, the Internet and Ordnance Survey Historical mapping (Figs. 3-13).

### **4.2 Map Regression 1769 - 1994**

4.2.1 In the A Drury, W Herbert Map of 1769 (Plate 9) the PDA is located in an area characterised by large hills or embankments set around the properties of 'Froghatt', 'Tudington', 'Cits Cote House' and 'Mouson Green'. The land is marked for the Earl of Aylesford. Aylesford village and the River Medway are to the south.

4.2.2 In the OS Surveyors Drawing map of 1798 the PDA is located in an area of open fields and within the land of Aylesford Place to the south. The west quarry is farmed as orchard or hop and the property of Lord Lees is northeast (Fig. 4).

4.2.3 In the OS Map of 1869 the PDA is within a patchwork of agricultural fields. A strip of land with a small stream and pond and scattered trees follow a circular pattern that may suggest a level change in the ground. 'The Friars erected 1240AD' is marked adjacent to the River Medway and 'Hospital of the Holy Trinity an Alms House dated 1607' is located within Aylesford village (Fig.7).

4.2.4 In the OS Map of 1896 a 'Sand Pit' has appeared to the north of St Peter's Church in the area of the east quarry and a Tramway leads from the Sand Pit to the 'Brick and Tile Works' to the west and onwards to the River Medway Quay. A note on the map confirms 'Two stone cists containing human remains found A.D.1886' within the Sand Pit. A second 'Sand Pit' is to the west within the area of the west quarry and on the site of a spring; a second tramway leads from the Sand Pit to the river. A 'Gold Armiloe found AD1861' is marked in fields on the north bank of the River Medway close to The Friars (Fig.9).

4.2.5 In the OS Map of 1907 the east Sand Pit has been extended and is now marked as the 'Site of Celtic Cemetery'. The Tramway has been removed. To the west, the Maidstone Corporation Sewage Works has been developed adjacent to the Sand Pit and the Tramway leads to the Wharf at the River Medway. Aylesford village has developed along the river and industry has moved into the area in the form of 'Chemical works' (Fig.9).



4.2.6 In the OS Map of 1931 the east quarry is marked 'Late Celtic urn field excavated 1886AD' and 'Bronze Age burials found 1886, 1889 and 1898AD' and has a new Tramway that leads directly to the river. The west quarry is marked as 'Nicopits (Sand)', the Tramway has been removed but an 'Engine House' has been added to the sewage works; Aylesford Sewage works (Malling R.D.C) has opened to the north (Fig.8)

In the OS Map of 1938 the east quarry has a small rectangular structure (Fig. 10) and in the OS Map of 1948 there has been very little change (Fig.11) and of 1961 (Fig. 12)

#### *4.2.7 Aerial Photographs*

The study of the collection of aerial photographs held by Google Earth was undertaken. In 1940 the PDA is predominantly formed by agricultural fields and the quarries east and west of Bull Lane (Plate 1). The sewage works is visible adjacent to the west quarry. In 1960 the east quarry has spread to the west of Bull Lane and the sewage works have developed further with access leading to the River Medway. The area south of the river has undergone substantial industrial and residential development (Plate 2).

4.2.8 In 1990 the east quarry has filled with water and the area surrounding it has been cultivated with grassland and trees. The quarry to the west of Bull lane has continued to spread west joining the west quarry to create one large quarry and has part filled with water. An industrial area has been developed east of the Rochester Road (Plate 3). By 2003 both quarries are filled with water and a smaller third quarry has opened north of the east quarry. By 2006 the water level of each quarry has increased and part of the third quarry has also been flooded and by 2015 all three quarries are flooded (Plates 4-5).

## 5 ARCHAEOLOGICAL AND HISTORICAL DEVELOPMENT

### 5.1 Introduction

Prehistoric	Palaeolithic	c. 500,000 BC – c.10,000 BC
	Mesolithic	c.10,000 BC – c. 4,300 BC
	Neolithic	c. 4,300 BC – c. 2,300 BC
	Bronze Age	c. 2,300 BC – c. 600 BC
	Iron Age	c. 600 BC – c. AD 43
Romano-British		AD 43 – c. AD 410
Anglo-Saxon		AD 410 – AD 1066
Medieval		AD 1066 – AD 1485
Post-medieval		AD 1485 – AD 1900
Modern		AD 1901 – present day

**Table 1 Classification of Archaeological Periods**

The Archaeological record within the assessment area is diverse and should comprise possible activity dating from one of the earliest human period in Britain through to the post-medieval period. The geographic and topographic location of Aylesford is within a landscape that has been the focus of trade, travel and communication since the Neolithic.

This section of the assessment will focus on the archaeological and historical development of this area, placing it within a local context. Each period classification will provide a brief introduction to the wider landscape, followed by a full record of archaeological sites, monuments and records within the site's immediate vicinity. Time scales for archaeological periods represented in the report are listed on the previous page in **Table 1**.

### 5.2 History of the site

5.2.1 Aylesford takes its name from the old English *Eeglesforda* meaning 'Aegel's Ford'. Quarrying began between 1865 and 1896, revealing the remains of mammals including mammoths, lions and bison and prehistoric tools. Bronze Age swords were found nearby and an Iron Age settlement and Roman Villa are known to have stood at the village of Eccles, suggesting continued occupation of the area from the earliest periods of human history.

5.2.2 Several chamber tombs can be found north of the village. 'Kits Coty house', is the remains of a burial chamber that is sited at one end of a long barrow. The monument is comprised of four large stones, three vertical and one sitting atop the former horizontally. It is approximately 11ft by 8ft and some 8ft high. To the south and lower down the hill are the remains of 'Little Kits Coty House' or 'Countless Stones', pile of stones that are fallen but arranged in a similar manner.

5.2.3 In 1886, an Iron Age cemetery was excavated by Arthur Evans, in which many artefacts were recovered including a bronze jug, pan and bucket with handles in the form of a human face from a cremation burial. A later excavation at Swarling gave rise to the 'Aylesford-Swarling' culture based on the Aylesford-Swarling pottery.

5.2.4 In 455AD Aylesford was the site of the Battle of Aylesford fought between the Britons and the Saxons some five years after the Saxons arrived in Britain and in which the Britons were victorious. The Saxon general Horsa, brother of Hengist and Catigern, brother of King Vortimer, fighting hand to hand, were both killed. Horsa is said to have been buried three miles north of Aylesford in a place known as Horsted or 'the place of Horsa'. There are many large stones dispersed over the fields nearby thought to indicate a burial ground. Catigern was buried one mile north of the village and a quarter of a mile west of the Rochester Road.

5.2.5 William the Conqueror took possession of Aylesford after the Norman invasion of 1066 and the church of St Peter and Paul, which is located on a hill to the south of the village is of Norman construction.

The Priory, also known as the Friars was founded in 1240 AD for the Carmelites just west of the village, on the north bank of the River Medway. It was confiscated by

the crown at the dissolution and then passed into private ownership. The Carmelite's purchased the property in 1949 and the head of the 12<sup>th</sup> century Prior General, Simon Stock, are retained at the friary.

5.2.6 In the 14<sup>th</sup> century one of the earliest bridges was built across the river Medway. The river was navigable as far as Maidstone until 1740 prompting the construction of the wharf at Aylesford close to the west quarry. The oldest buildings are on the north and south banks of the river. The Alms-houses date to 1607AD and the George was a former coaching Inn. Quarrying during the Victorian period brought further expansion to the village.

**5.3** This section of the assessment will focus on the archaeological and historical development of this area, placing it within a local context. Each period classification will provide a brief introduction to the wider landscape (500m radius centered on each site of the PDA), followed by a full record of archaeological sites, monuments and records within the site's immediate vicinity. Time scales for archaeological periods represented in the report are listed on page 15 in **Table 1**.

A preliminary review of the cultural heritage data shows that the site has **high** archaeological potential.

#### **5.4 Scheduled Monuments; Listed Buildings; Historic Parks & Gardens and Conservation Areas**

The PDA is located adjoining the Aylesford Village Conservation Area with none of the conservation area intruding into the PDA. Six events, four findspots, three monuments, one building, one farmstead are recorded within the confines of the proposed development area (PDA). Sixteen events, eighteen findspots, fifteen listed buildings, three monuments and one buildings are recorded within a c.500m vicinity of the PDA; Two listed buildings share intervisibility with the PDA. The Old Mill House (TQ75NW337) c.250m east of the PDA is a Grade II Listed house with construction periods ranging from 1600 to 1999. The Anchor Farm (TQ75NW127) is a post-medieval farmstead, c.400m east of the PDA with a 17<sup>th</sup> century farmhouse

and farm buildings that range from late 16<sup>th</sup> century to 19<sup>th</sup> century.

## **5.5 Walkover Survey**

A walkover survey by the writer of this report was accomplished on Monday 1<sup>st</sup> August 2016. Weather conditions were dry and overcast. The reason for the survey was to:

1. Identify any historic landscape features not shown on maps
2. Conduct a rapid survey for archaeological features
3. Make a note of any surface scatters of archaeological material
4. Constraints or areas of disturbance that may affect archaeological investigation

The walkover survey was not intended as a detailed survey but the rapid identification of archaeological features and any evidence for buried archaeology in the form of surface scatters of lithic or pottery artifacts.

The PDA consists of an area not previously quarried and adjacent to land containing three former quarries. The Rochester Road is east, the River Medway to the south. (Plates 7-8). The site varies in level from 3m -7m OD. The fields were walked with no archaeological remains or artefacts in the fields.

## **6. ARCHAEOLOGICAL POTENTIAL**

### **6.1 Palaeolithic, Mesolithic, Neolithic and Bronze Age**

The Palaeolithic represents the earliest phases of human activity in the British Isles, up to the end of the last Ice Age. Palaeolithic dated material occurs in north and east Kent, especially along the Medway and Stour Valleys. The Kent HER has eleven records of archaeological evidence relating to this period within the assessment area.

6.1.1 Palaeolithic flints and mammalian remains have been found at Aylesford sand quarry (TQ75NW22) within the PDA and are now held at the Maidstone Museum.



Flakes and hand-axes collected by Burchell (TQ75NW176) and nine Palaeolithic flint hand-axes and two scrapers (TQ75NW126) have been found c.450m southwest of the PDA. Tunbridge Wells museum holds sixteen hand axes from the same site. Flint flakes and hand-axes discovered in 1916 (TQ75NW175) c.450m southwest are held at the Rochester Museum; sixteen hand-axes, part of the Sturge collection, one annotated 'brick earth' and another '1889' (TQ75NW177), a large number of finds from the Christy collection (ex Franks collection) annotated with '1884' and '1895' (TQ75NW178), the Wellcome collection annotated with '1914', '1936', '1937' and '1938' (TQ75NW180), hand-axes annotated with '1896' part of the Institute of Archaeology collection (TQ75NW182), the Harrison collection (TQ75NW179), the Warren collection (ex-Elliot collection) (TQ75NW181) and two hand axes, part of the Todd-White collection (TQ75NW181) all found c.450m southwest are held by the British Museum. Two struck flints were found on a watching brief in 2001 (TQ75NW144) c.300m northwest.

6.1.2 The Mesolithic period reflects a society of hunter-gatherers active after the last Ice Age. The Kent HER has three records of archaeological evidence from this period within the assessment area. A tranche axe found in the 1970's (TQ75NW64) held at the Dartford museum, a second tranche axe held at the Maidstone Museum (TQ75NW99) and a blade (TQ75NW65) held at the Rochester Museum were found c.450m southwest of the PDA.

6.1.3 The Neolithic period, the beginning of a sedentary lifestyle based on agriculture and animal husbandry, is represented within the assessment area by one record. Two stone axes (TQ75NW53), one chipped and one polished, found c.450m southwest of the PDA, are held at Cambridge University Museum.

6.1.4 The Bronze Age was a period of large migrations from the continent and more complex social developments on a domestic, industrial and ceremonial level. There are three records in the Kent HER within the assessment area for this period. In the 19<sup>th</sup> century Bronze age burials were found on the east of the gravel pit and three cists containing Bronze Age crouched burials were found on the western side (TQ75NW55) within the PDA.

A leaf-shaped sword (TQ75NW36) held at the Ashmolean Museum, Oxford and four looped and socketed axes, one with a square mouth and three ribs on the face, another with bevelled sides and a splayed cutting edge (TQ75NW37) were all found c.450m southwest.

6.1.5 The potential for finding remains that date prior to the Iron Age within the confines of the proposed development is therefore considered **high**.

## 6.2 Iron Age

The Iron Age is, by definition a period of established rural farming communities with extensive field systems and large 'urban' centres (the Iron Age 'Tribal capital' or *civitas* of the Cantiaci, the tribe occupying the area that is now Kent, was Canterbury). The Kent HER has two records of archaeological evidence within the assessment area. A late Iron Age cremation cemetery (TQ75NW21) and two stone cists containing human remains were found in 1886 in a sand pit, within the PDA and a Belgic bronze torc (TQ75NW48) found in the River Medway and held at the Maidstone Museum was found, c.450m southwest, therefore the potential for finding remains that date to this period within the confines of the development site is considered **moderate**.

## 6.3 Romano-British

The Romano-British period is the term given to the Romanised culture of Britain under the rule of the Roman Empire, following the Claudian invasion in AD 43, Britain then formed part of the Roman Empire for nearly 400 years.

The predominant feature of the Roman infrastructure within Kent is arguably the extensive network of Roman roads connecting administrative centres: the towns to military posts and rural settlements (villas, farmsteads and temples) increasing the flow of trade, goods, communications and troops. Canterbury or *Durovernum Cantiacorum* was a major town of the Roman province of Britannia and the regional capital.

6.3.1 There are three records relating to this period within the assessment area. A coin of Antoninianus of Gordian III (TQ75NW57/100) was found in 1970 in a garden at Vicarage Close, within the PDA. Aerial photographs of Tottington Farm, a geophysical survey in 1998 and excavations in 1991 (TQ75NW82) within the PDA revealed an asymmetrical, rectilinear enclosure with rounded corners and a square feature inside suggesting late Iron Age/early Romano-British occupation.

6.3.2 The geophysical survey was carried out by the Clark Laboratory, Museum of London Archaeology Service in August-September 1998 following removal of the crop. The magnetometer survey was supplemented by a magnetic susceptibility survey with readings taken at 10m intervals using a Bartington MS2 meter and field sensor coil.

The survey confirmed the features shown on an aerial photograph supplied by KCC and showed an additional enclosure, one of which was not shown on the aerial photograph and was located at the north west corner of the survey (Appendix 1).

6.3.3 As part of the research for the Desk-based Assessment (DBA) a search was made for crop marks in the vicinity of the PDA and about 900m to the north the 1970 GoogleEarth series shows a prehistoric field system possibly Bronze Age which shows a number of rectangular fields with collecting pens, funnel or crush, a race and then drafting gates to separate lambs from ewes (Plates 9-10).

6.3.4 To the north west of the PDA a sub-rectangular enclosure with additional round circles was also identified on the 1970 GoogleEarth series (Plate 11).

6.3.5 In 1999 Canterbury Archaeological Trust conducted an archaeological evaluation to the north of the PDA but on the same area as the geophysical survey (6.3.2). Trenches 1-3 contained no archaeology but in the remaining trenches pits and ditches were found and dated by pottery to the Late Iron Age-Early Roman period (mid 1<sup>st</sup> century BC to mid to late 1<sup>st</sup> century AD) although some features may be of prehistoric origin. There was no physical evidence for any structures or building foundations but the findings of *opus signinum* a type of Roman waterproof

pink mortar used for floors of villas and bath house plus the finding of a Roman ridge tile and Roman domestic waste does suggest there is a Roman building in the near vicinity (Appendix 2).

6.3.6 Given the geophysical survey and follow on archaeological evaluation actually within the proposed development area the potential for finding archaeological features or deposits from this period is considered **high**.

#### **6.4 Anglo-Saxon**

There is one record dating to the Anglo-Saxon period within the assessment area. A Saxon bronze buckle (TQ75NW20) was found on the Rochester road in the 1950's, c.400m southeast. Therefore, it is reasonable to conclude that the potential for finding remains dating to the Anglo-Saxon period in the PDA can be considered as **low**.

#### **6.5 Medieval**

There is one record dating to the medieval period within the assessment area. The Church of St Peter (TQ75NW24) is a Grade I listed building dating prior to 1145AD with later medieval alterations, c.500m south west of the PDA. Therefore the potential for finding remains dating to the medieval period is considered as **low**.

#### **6.6 Post Medieval to Modern**

The post-medieval period is well represented within the assessment area. Three buildings (TQ75NW135) dating to the 19<sup>th</sup> century survive at Aylesford quarry, tile, brick and pottery were found during a watching brief (TQ75NW144) in 2001 and a sand mine (TQ75NW402) with a 7m shaft and chamber was found to the rear of 32 Mount Pleasant, all within the PDA. The Old Mill House (TQ75NW337) is a Grade II listed building dating from 1600-1999, c.200m east of the PDA. A small arched tunnel (TQ75NW129) in yellow brick leads under the Rochester Road to the Aylesford quarry, c.350m south (Plates 20-21).

The Grade II listed arch and wall to the north of Trinity Court (TQ75NW229) constructed between 1607-1999, Alms-house of Trinity Court (TQ75NW308), dating from 1607-1892, 22-32 Mount Pleasant (TQ75NW271), dating from 1860-1870, the Methodist Church and Sunday School (TQ75NW341), dating from 1830-1870 are all found c.400m south.

Excavations at St Peters C of E School Annexe (TQ75NW120) at the Old Vicarage, revealed a 3-chambered cellar of brick construction and a pond and remains of the the 18<sup>th</sup>/19<sup>th</sup> century vicarage (TQ75NW351) were found during a watching brief at St Peter's School, c.400m southwest. Two Grade II listed Chest tombs (TQ75NW257/263/264/239/296/ 309) dating between 1700-1732 and a table tomb dating from 1733-1766 (TQ75NW295/310/311) are all sited to the south east of Aylesford Church and c.400m south west.

The Grade II listed cast iron village water pump (TQ75NW240), dating from 1833 to 1866, is sited 10 yards east of Trinity Court, is c.400m south, 24 and 26 High Street, dating to 1767, is c.450m south west and Dorothy's House (TQ75NW253), dating to 1700-1732, is c.500m south. A tomb monument (TQ75NW251) dated 1891 is recorded 40 yards north west of Aylesford church, c.500m south west.

The environment around the PDA was largely agricultural. Anchor Farm (TQ75NW127/MKE84629) is a post-medieval farmstead located on the Rochester Road, c.400m east. It is a dispersed cluster of buildings with oast and detached farmhouse in an isolated position with less than 50% loss of original form. A field barn (MKE84630) with no associated yard is south west of Anchor farm, in an isolated position but within the PDA. The farmstead is completely demolished. The potential for finding remains dating to the post-medieval to modern period is therefore considered as **high**.

## 6.7 Summary of Potential

The desk-based assessment has considered the archaeological potential of the site but this potential can only be tested by fieldwork. Research has shown that the PDA may contain archaeological sites and these can be summarised as:



- Prehistoric: **High**
- Iron Age: **Moderate**
- Roman: **High**
- Anglo-Saxon: **Low**
- Medieval: **Low**
- Post-Medieval and Modern: **High**

## 7. IMPACT ASSESSMENT

### 7.1 Introduction

Cartographic Regression, Topographical Analysis, and Historic Research have provided evidence for the historic use of the site. By collating this information we have assessed the impact on previous archaeological remains through the following method of categorisation:

- **Total Impact** - Where the area has undergone a destructive process to a depth that would in all probability have destroyed any archaeological remains e.g. construction, mining, quarrying, archaeological evaluations etc.
- **High Impact** – Where the ground level has been reduced to below natural geographical levels that would leave archaeological remains partly in situ either in plan or section e.g. the construction of roads, railways, buildings, strip foundations etc.
- **Medium Impact** – Where there has been low level or random disturbance of the ground that would result in the survival of archaeological remains in areas undisturbed e.g. the installation of services, pad-stone or piled foundations, temporary structures etc.
- **Low Impact** – Where the ground has been penetrated to a very low level e.g. farming, landscaping, slab foundation etc.

## **7.2 Existing Impacts**

7.2.1 Cartographic regression (4.1.3), Topographic analysis (4.1.4) and Historical research (5.2) indicate that the site has largely been the subject of quarrying. Therefore, previous impacts to archaeological remains from quarrying are considered to be **high**.

7.2.2 Agriculture became gradually more intense over time and by the modern era it was mechanised. Although the farming process rarely penetrates below the upper layers of the ground, plough truncation can have a significant impact on preserved shallow deposits. The fields around the quarry site have been farmed for over 250 years, therefore the residual impact of the agricultural process on buried archaeology is considered to be **high**.

## **7.3 Proposed Impacts**

7.3.1 The general development of the site  
At the time of preparing this archaeological assessment, the extent of the proposed development was for the construction of residential housing, associated access roads and landscaping.

7.3.2 The very nature of construction will have a negative impact on below ground archaeological deposits through the movement of plant, general ground disturbance and contamination and excavation. Therefore, extensive impact can be expected within the development area once construction begins.

## **8. MITIGATION**

The purpose of this archaeological desk-based assessment was to provide an assessment of the contextual archaeological record, in order to determine the potential survival of archaeological deposits that may be impacted upon during any proposed construction works.

The assessment has generally shown that the area to be developed is within an area of **high** archaeological potential. In areas that can be shown to have had little previous impacts a programme of archaeological mitigation will be required to a archaeological specification and timetable agreed with the local planning authority.

## **9. OTHER CONSIDERATIONS**

### **Setting of Listed Buildings**

One of the tasks of the site visit was aimed to identify any designated heritage assets within the wider context of the PDA in accordance with *The Setting of Heritage Assets – English Heritage Guidance* (English Heritage 2011). This guidance states that “*setting embraces all of the surroundings (land, sea, structures, features and skyline) from which the heritage asset can be experienced or that can be experienced from or with the asset*” (The Setting of Heritage Assets, English Heritage 2011).

There are no Listed Buildings within the PDA (Plate 12). The listed buildings are mostly found c.4-500m south and southwest. The PDA shares intervisibility with two Listed Buildings. The Old Mill House (TQ75NW337) is located c.100m east and Anchor farm (TQ75NW127) is located c.300m east.

#### **9.1 Archive**

Subject to any contractual requirements on confidentiality, two copies of this desk-based assessment will be archived with SWAT Archaeology.

#### **9.2 Reliability/Limitations of Sources**

The sources that were used in this assessment were, in general, of high quality. The majority of the information provided herewith has been gained from either published texts or archaeological ‘grey’ literature held at Kent County Council, and therefore considered as being reliable.

#### **9.3 Copyright**

Swale & Thames Survey Company and the author shall retain full copyright on the commissioned report under the Copyright, Designs and Patents Act 1988. All rights

are reserved, excepting that it hereby provides exclusive licence to Aylesford Heritage Ltd for the use of this document in all matters directly relating to the project.

Paul Wilkinson PhD., MCifA., FRSA.

17<sup>th</sup> October 2017

## **10 REFERENCES & BIBLIOGRAPHY**

IFA (2014) STANDARD AND GUIDANCE for historic environment desk-based assessment.

Hull, F. (1988) Ordnance Survey Historical Guides: Kent. Philip, London & Ordnance Survey, Southampton.

National Planning Policy Framework 2012.

Data provided by Kent HER

**APPENDIX 1 ARCHAEOLOGICAL SITES**

<b>KHER Ref</b>	<b>Type</b>	<b>Location</b>	<b>Period</b>	<b>Description</b>
EKE11542	Event	N/a	Post-medieval	Watching brief, 2011, Alan Ward, St Peter's School, found remains of the 18 <sup>th</sup> /19 <sup>th</sup> century vicarage.
EKE13056	Event	c.250m E	N/a	DBA, 2010, Halcrow Group Ltd, Aylesford Flood Alleviation Scheme
EKE13132	Event	c.400m S	Post-Medieval	Field Survey, 2006, Kent Underground Research Group, Sand Mine at the rear of 32 Mount Pleasant
EKE5098	Event	c.500m SW	Post-Medieval	Excavations, 1994, Maidstone Area Archaeological Group, St Peters C of E School, 3-chambered cellar of brick construction and pond and a building that pre-dates the vicarage.
EKE5353	Event	c.150m W	N/a	Evaluation, 1999, Canterbury Archaeological Trust, Tottington Farm.
EKE5759	Event	c.150m W	Modern	Watching Brief, 2001, Canterbury Archaeological Trust, Aylesford Sand Quarry.
EKE8464	Event	c.50m N	Undated	Geophysical Survey, 1998, Clark Laboratory, Tottington Farm, cropmarks, small enclosure and main enclosure.
EKE10636	Event	N/a	Post-Medieval	Watching brief, 2008, Alan Ward, St Peter's School, ragstone and brick walling, a cellar and a culvert 18 <sup>th</sup> /19 <sup>th</sup> century.
EKE3950	Event	c.200m W	Iron Age	Excavation, 1986, Ashmolean Museum, Parish Field, Belgic Cemetery.
EKE14367	Event	c.200m W	Undated	Test pit, 2007, University of Southampton, Asheldham Quarry, Medway Valley Palaeolithic Project.
EKE9483	Event	c.500m S	Undated	DBA, 2007, University of Southampton, Medway Valley Palaeolithic Project, review of 1916 finds held by the Rochester Museum.
EKE9484	Event	N/a	Undated	DBA, 2007, University of Southampton, Medway

				Valley Palaeolithic Project, review of Burchell collection held by the British Museum.
EKE9485	Event	N/a	Undated	DBA, 2007, University of Southampton, Medway Valley Palaeolithic Project, review of Sturge collection held by the British Museum.
EKE9486	Event	N/a	Undated	DBA, 2007, University of Southampton, Medway Valley Palaeolithic Project, review of Christy collection held by the British Museum.
EKE9487	Event	N/a	Undated	DBA, 2007, University of Southampton, Medway Valley Palaeolithic Project, review of Harrison collection held by the British Museum.
EKE9488	Event	c.500m S	Undated	DBA, 2007, University of Southampton, Medway Valley Palaeolithic Project, review of Wellcome collection held by the British Museum.
EKE9489	Event	N/a	Undated	DBA, 2007, University of Southampton, Medway Valley Palaeolithic Project, review of Warren collection held by the British Museum.
EKE9490	Event	c.500m SW	Undated	DBA, 2007, University of Southampton, Medway Valley Palaeolithic Project, review of Todd-White collection held by the British Museum.
EKE9491	Event	c.500m S	Undated	DBA, 2007, University of Southampton, Medway Valley Palaeolithic Project, review of Institute of Archaeology collection held by the British Museum.
EKE9575	Event	c.200m W	Undated	DBA, 2007, University of Southampton, Medway Valley Palaeolithic Project, review of Jessop collection held by the Maidstone Museum.
EKE10037	Event	c.250m east	Undated	Watching Brief, 2004, Canterbury Archaeological Trust, Old Mill House.
EKE9002	Event	c.400m S	Post-medieval	Watching Brief, 2005, Archaeology South-east, St Peter's C of E Primary School, Brick, chalk and ragstone walls, probably 18 <sup>th</sup> century vicarage demolished 1957.
TQ75NW20	Findspot	c.400m S	Anglo-Saxon –	Saxon buckle found 1950's at Rochester Road

			Medieval	
TQ75NW21	Monument	c. 150m W	Iron Age	Iron Age cremation cemetery at Parish Field, two stone cists containing human remains found 1886.
TQ75NW22	Findspot	c.150m W	Palaeolithic	Palaeolithic flints found at the sand pit.
TQ75NW24	Listed Building	c.500m SW	Medieval	Grade I listed, Church of St Peter, pre 1145.
TQ75NW36	Findspot	c.500m SW	Bronze Age	Leaf shaped sword held at Ashmolean Museum Oxford, Evans collection.
TQ75NW37	Findspot	c.500m SW	Bronze Age	Four looped and socketed axes before 1930 held at British Museum.
TQ75NW48	Findspot	c.500m SW	Iron Age	Belgic bronze torc found in the River Medway.
TQ75NW53	Findspot	c.500m SW	Neolithic	Two Neolithic stone axes held at Cambridge University Museum.
TQ75NW55	Monument	c.150m W	Bronze Age	Bronze Age burials found on east side of gravel pit, three cists containing crouched burials held at Maidstone Museum.
TQ75NW57	Findspot	C,200m W	Roman	Coin of Antoninianus of Gordian III found at Vicarage Close 1970's.
TQ75NW64	Findspot	c.500m SW	Mesolithic	Tranchet axe held at Dartford Museum.
TQ75NW65	Findspot	c.500m SW	Mesolithic	Blade held at Rochester museum
TQ75NW82	Monument	c.100m N	Iron Age - Romano British	Crop marks of enclosure ditch, geophysical survey found a second smaller enclosure, excavations found ditches and pits, opus signinum, ridge tiles and domestic waste.
TQ75NW99	Findspot	c.500m SW	Mesolithic	Tranchet axe held at Maidstone Museum
TQ75NW100	Findspot	C,150m S	Romano-British	Coin of Antoninianus of Gordian III found at 2 Vicarage close in 1970's.
TQ75NW129	Building	c.350m SW	Post-medieval	Tunnel adjacent to 36 Rochester Road leading to quarry.
TQ75NW120	Monument	c.400m SW	Post-medieval	Post medieval building remains, 3-chambered cellar dating to 1750.
TQ75NW126	Findspot	c.500m SW	Palaeolithic	Nine flint hand axes and two scrapers.

TQ75NW127	Listed Building	c.400m E	Post-medieval	Gii Listed Anchor Farm, Rochester Road, farmstead.
TQ75NW135	Building	c. 150m W	Post-medieval	Three buildings at Aylesford quarry, workshops.
TQ75NW144	Findspot	c.150m W	Palaeolithic- Modern	2 struck flints, post-medieval tile, brick and pottery found on a watching brief in 2001.
TQ75NW251	Listed Building	c.500m SW	Post-medieval	GII listed Brassey tomb monument, 1891
TQ75NW253	Listed Building	c.400m S	Post-medieval	GII listed Dorothy's House, 1700-1732
TQ75NW229	Listed Building	c.400m S	Post-medieval	GII listed arch and wall to the north of trinity court, 1607-1999.
TQ75NW240	Listed Building	c.400m S	Post-medieval	GII listed village pump 10 yards east of trinity court, 1833-1866.
TQ75NW239	Listed Building	c.500m SW	Post-medieval	GII listed chest tomb 1700-1732
TQ75NW263	Listed Building	c.500m SW	Post-medieval	GII listed chest tomb 1700-1732
TQ75NW257	Listed Building	c.500m SW	Post-medieval	GII listed chest tomb 1700-1732
TQ75NW270	Listed Building	c.500m SW	Post-medieval	GII listed 24 and 26 High Street 1767
TQ75NW271	Listed Building	c.400m S	Post-medieval	GII listed 22-32 Mount pleasant 1860-1870
TQ75NW264	Listed Building	c.400m SW	Post-medieval	GII listed chest tomb 1700-1732
TQ75NW308	Listed Building	c.400m S	Post-medieval	GII listed Trinity Court 1607-1892
TQ75NW309	Listed Building	c.500m SW	Post-medieval	GII listed chest tomb 1700-1732
TQ75NW310	Listed Building	c.500m SW	Post-medieval	GII listed chest tomb 1733-1766
TQ75NW311	Listed Building	c.400m SW	Post-medieval	GII listed chest tomb 1733-1766
TQ75NW295	Listed Building	c.500m SW	Post-medieval	GII listed chest tomb 1733-1766
TQ75NW296	Listed Building	c.400m SW	Post-medieval	GII listed chest tomb 1700-1732
TQ75NW341	Listed Building	c.400m S	Post-medieval	GII listed Methodist church 1830-1870
TQ75NW337	Listed Building	c.200m E	Post-medieval	GII listed Old Mill house 1600-1999
TQ75NW175	Findspot	c.500m SW	Palaeolithic	Flake and hand-axes discovered 1916 held at Rochester Museum.
TQ75NW176	Findspot	c.500m SW	Palaeolithic	Flake and hand-axes, Burchell collection held at Rochester Museum.
TQ75NW177	Findspot	c.500m SW	Palaeolithic	Sixteen hand-axes Sturge collection held at the British Museum.



TQ75NW178	Findspot	c.500m SW	Palaeolithic	Palaeolithic artefacts, Christy collection held at the British Museum.
TQ75NW179	Findspot	c.500m SW	Palaeolithic	Palaeolithic artefacts, Harrison collection held at the British Museum.
TQ75NW180	Findspot	c.500m SW	Palaeolithic	Palaeolithic artefacts, Wellcome collection held at the British Museum.
TQ75NW181	Findspot	c.500m SW	Palaeolithic	Palaeolithic artefacts, Warren collection held at the British Museum.
TQ75NW181	Findspot	c.500m SW	Palaeolithic	Palaeolithic artefacts, Todd-White collection held at the British Museum.
TQ75NW182	Findspot	c.500m SW	Palaeolithic	Palaeolithic artefacts, Institute of Archaeology collection held at the British Museum.
TQ75NW351	Monument	c.400m SW	Post-Medieval	St Peter's School, Site of 18 <sup>th</sup> -19 <sup>th</sup> century vicarage.
MKE84629	Farmstead	c.400M E	Post-Medieval	Anchor Farm farmstead
MKE84630	Farmstead	c.200m W	Post-Medieval	Outfarm field barn.
TQ75NW402	Monument	c.250m W	Post-medieval	A sand mine with 7m shaft and chamber at 32 Mount Pleasant.

## Plates



Plate 7. View of PDA (looking north)



Plate 8. View of PDA (looking north-west)



Plate 9. AP 2007 showing Prehistoric field systems to the north of the PDA



Plate 10. Closer view of collecting pens, funnel or crush, race and drafting gates



Plate 11. AP 2007 view of enclosures and ring ditches





Figure 1: Site location map, scale 1:20000.



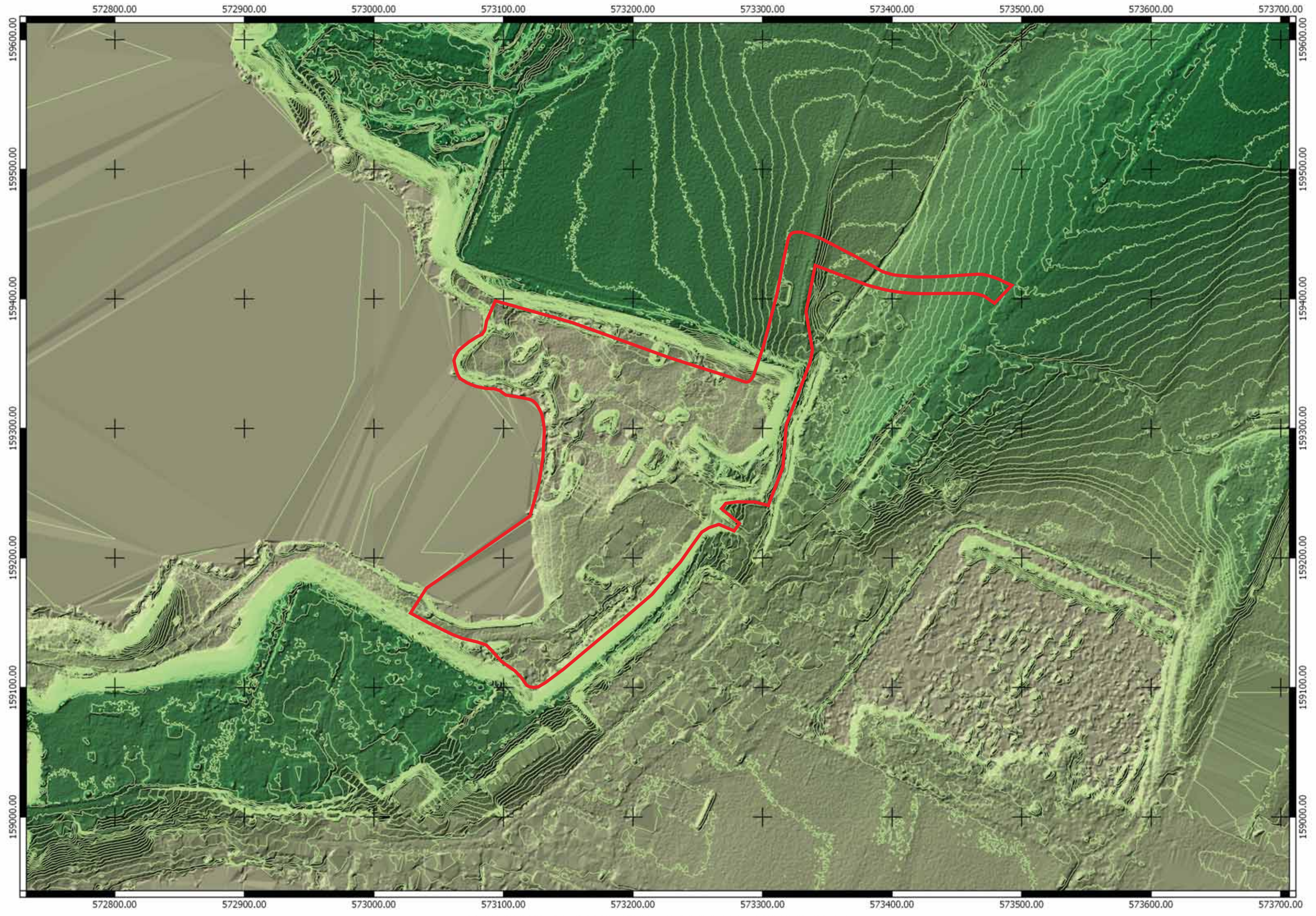

Figure 2: Digital surface model based on lidar data, scale 1:2500@A3



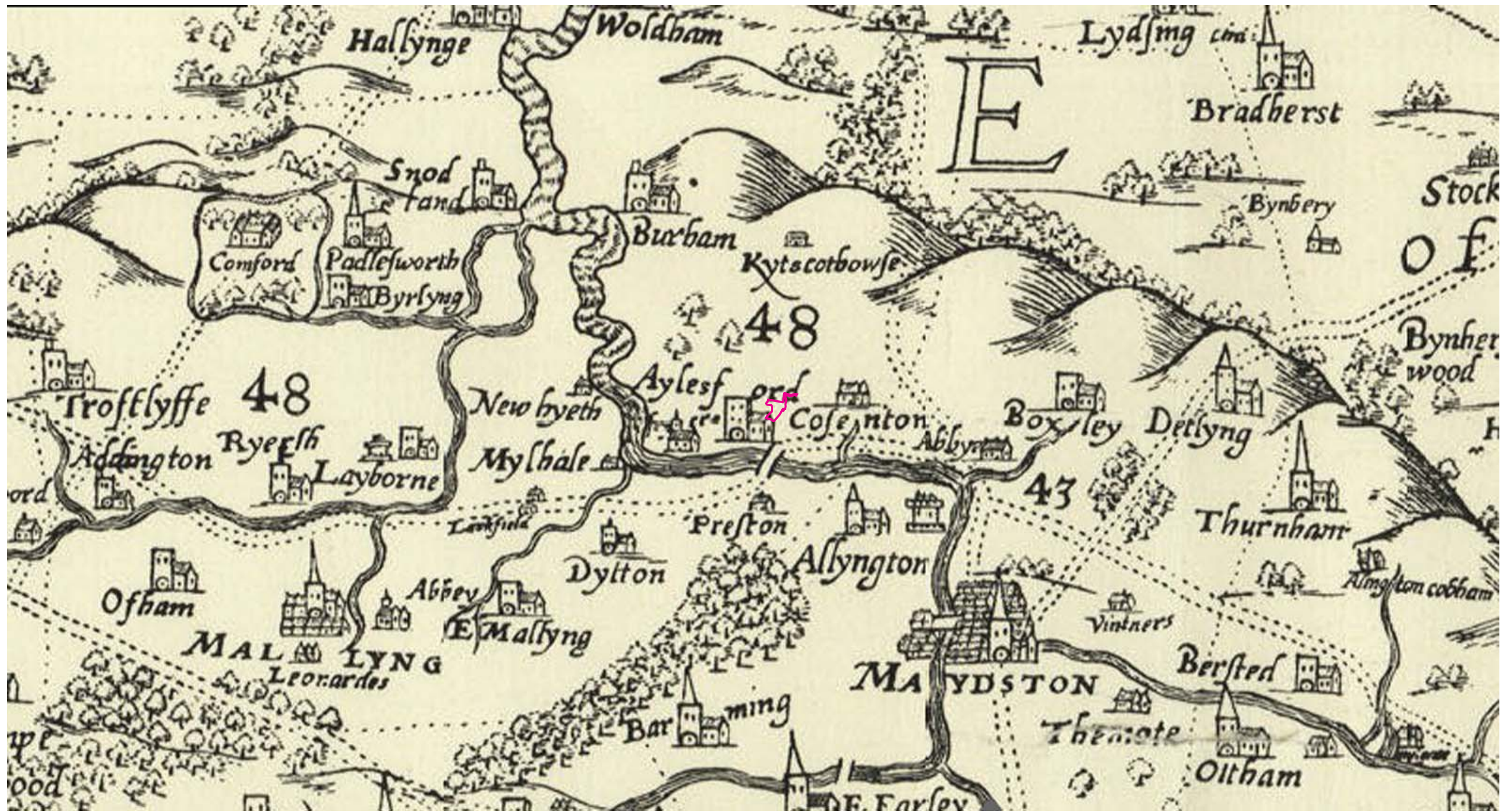

Figure 3: Symonson's Map of Kent 1596



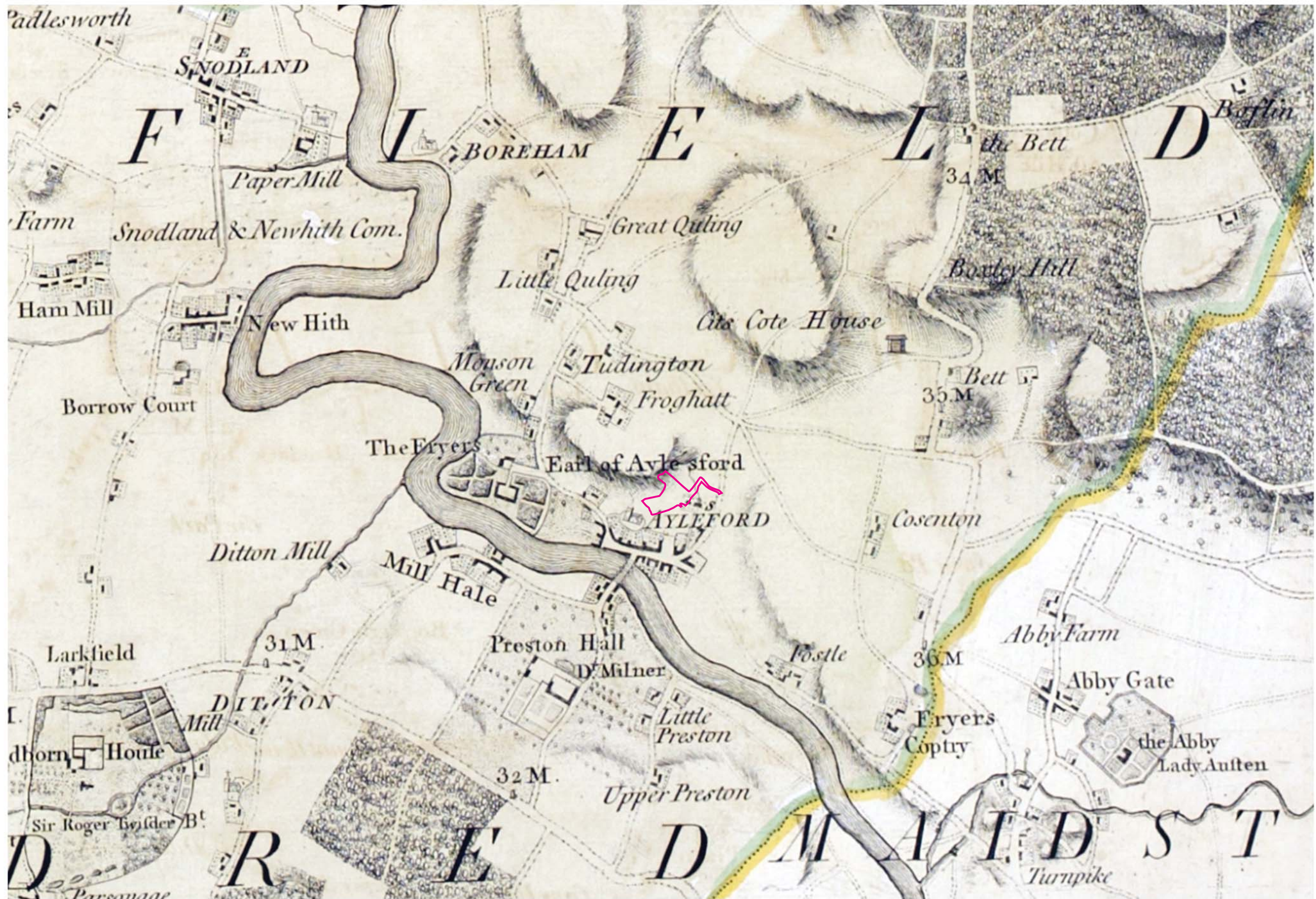

Figure 4: Topographical-map of the county of Kent from 1769, Publisher: A. Dury, W. Herbert.



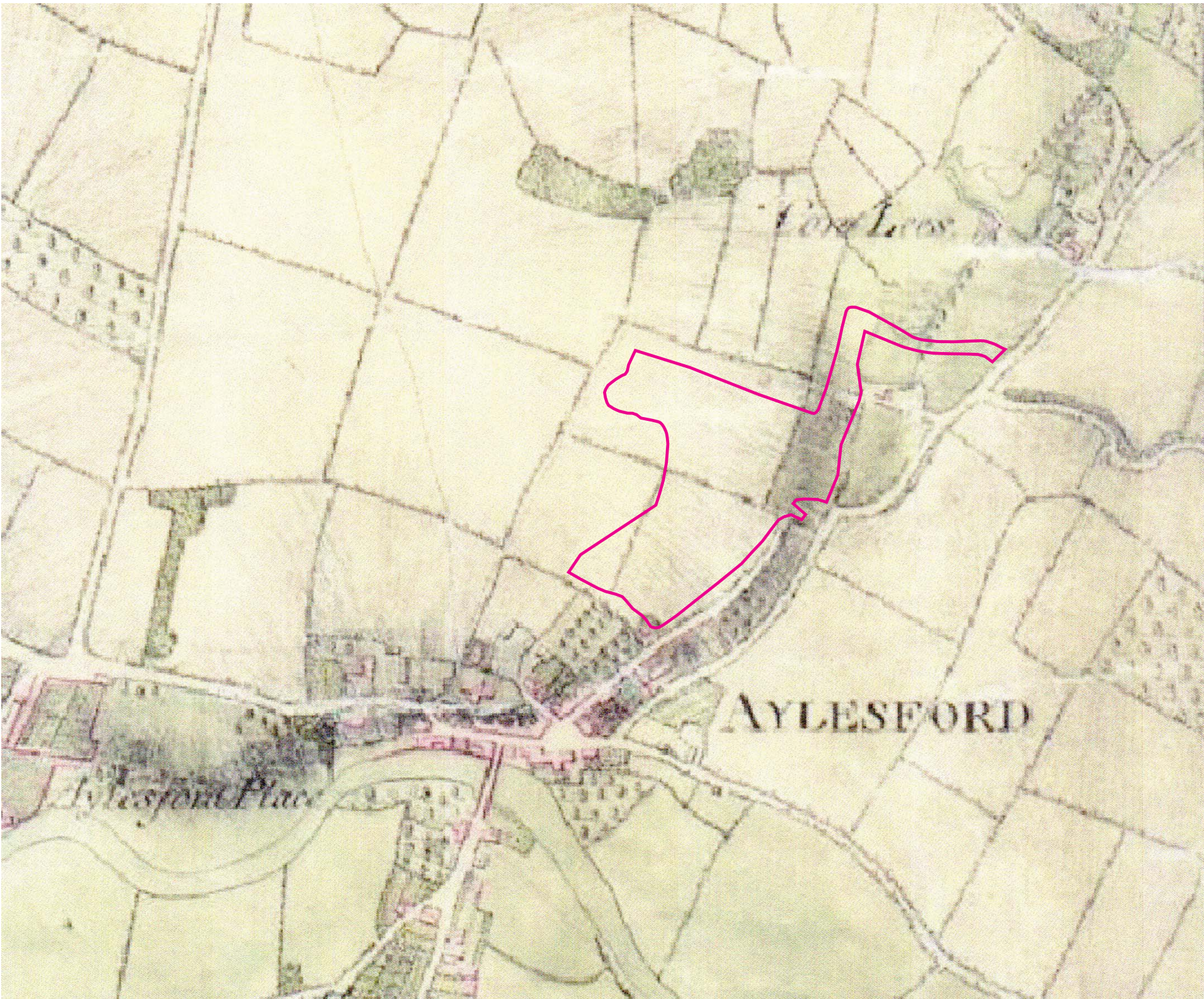

Figure 5: OS Surveyors drawing from 1769.

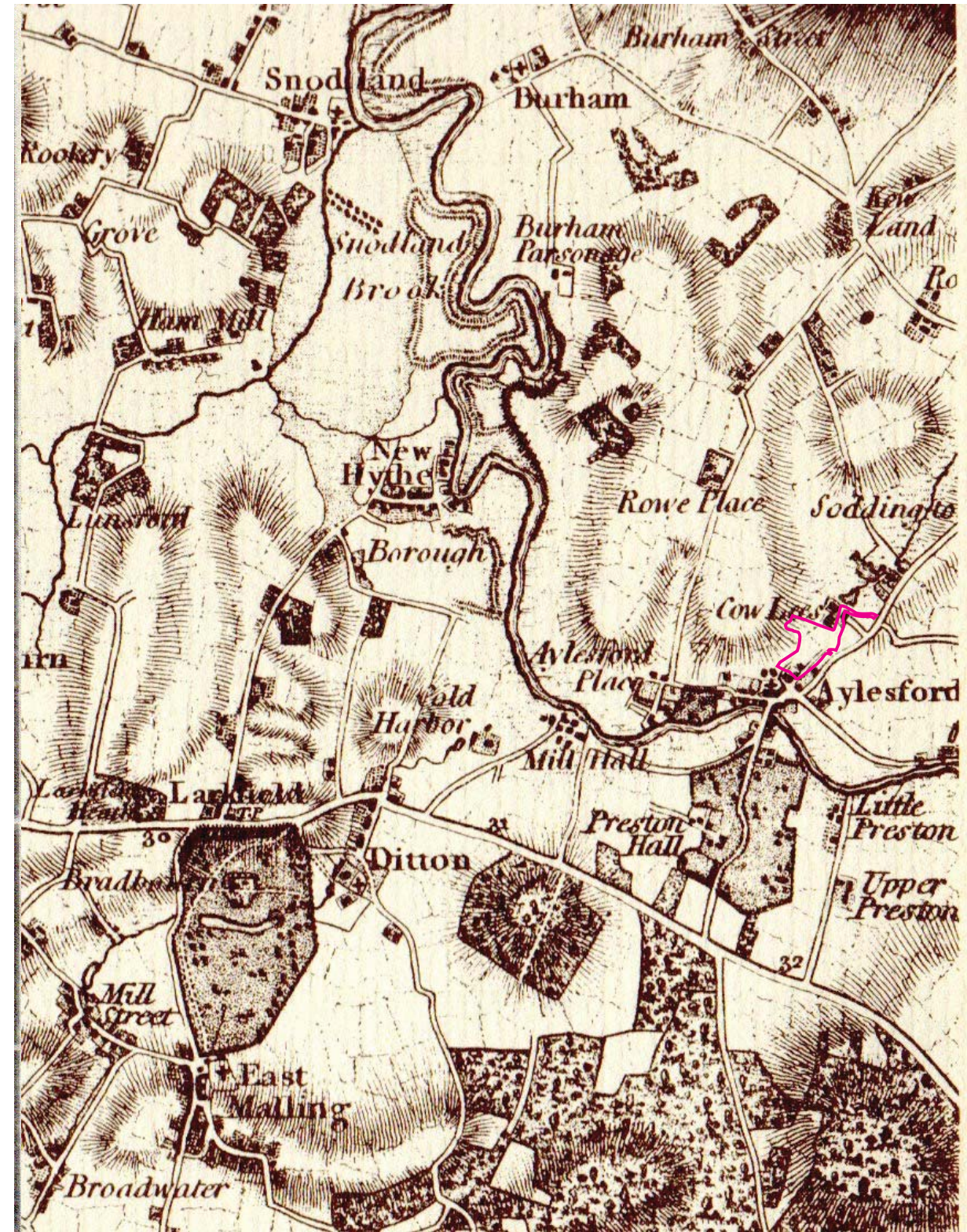

Figure 6: OS map, first edition from 1798.







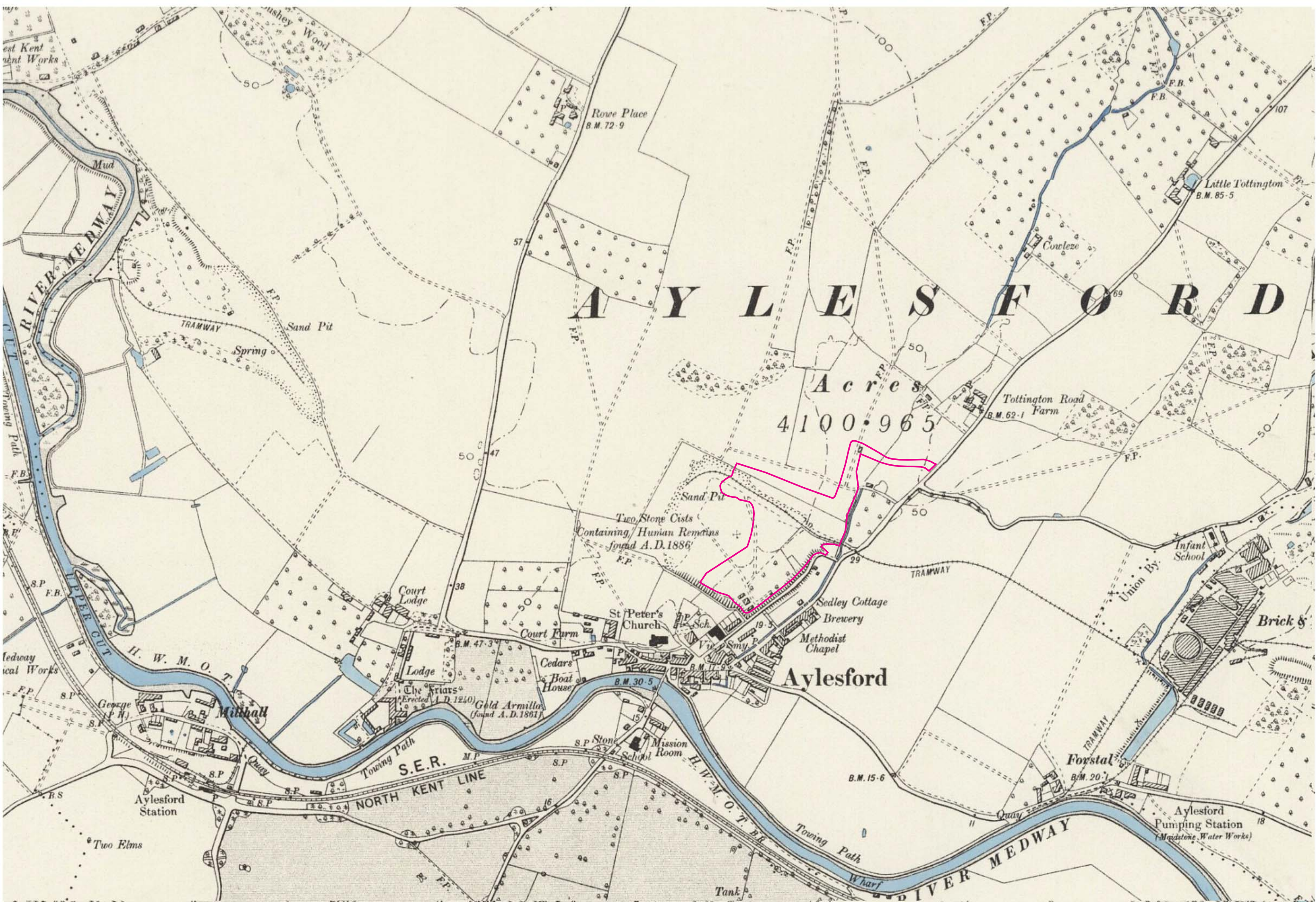

Figure 8: OS map from 1896, scale 1:6666



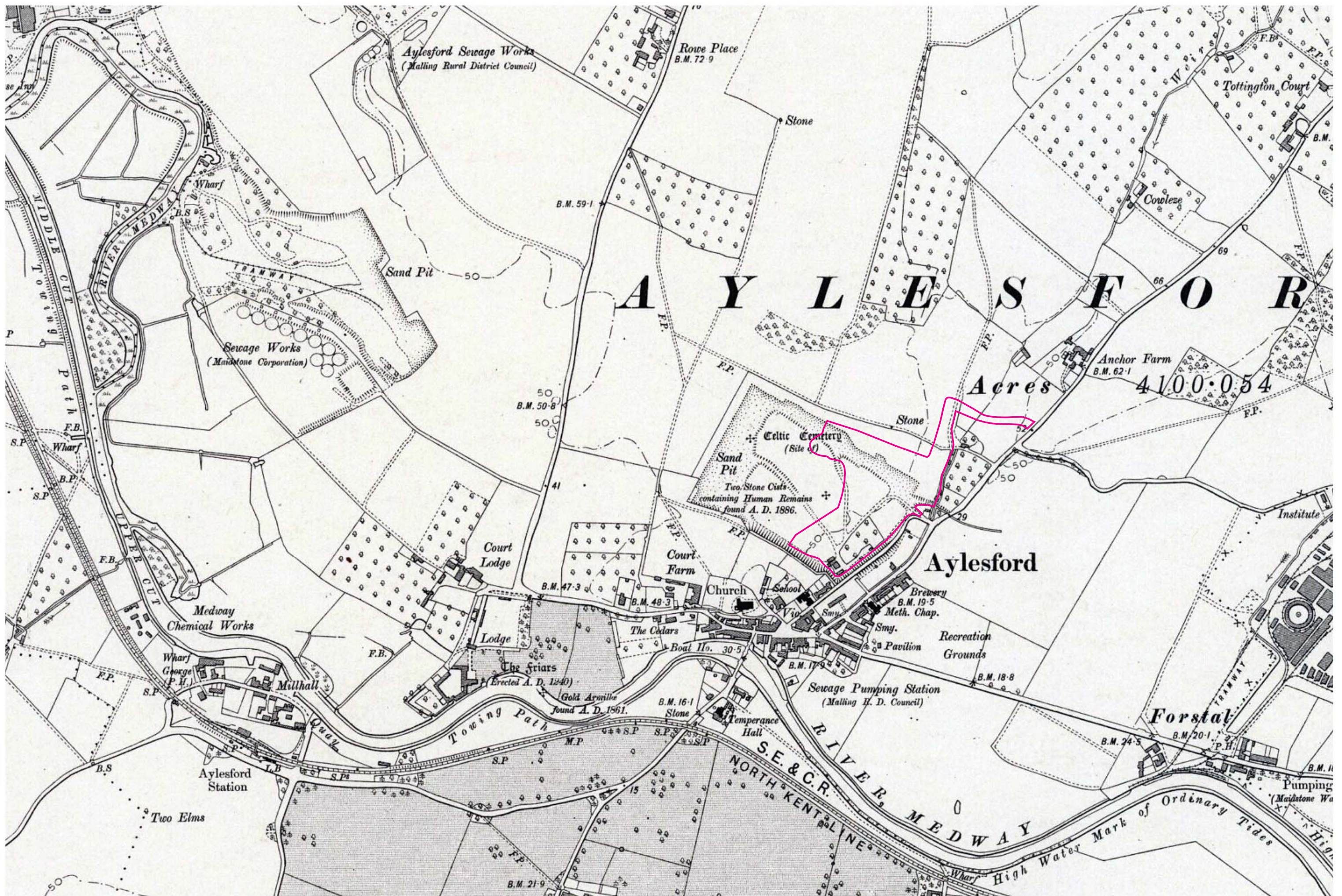

Figure 9: OS map from 1907, scale 1:6666



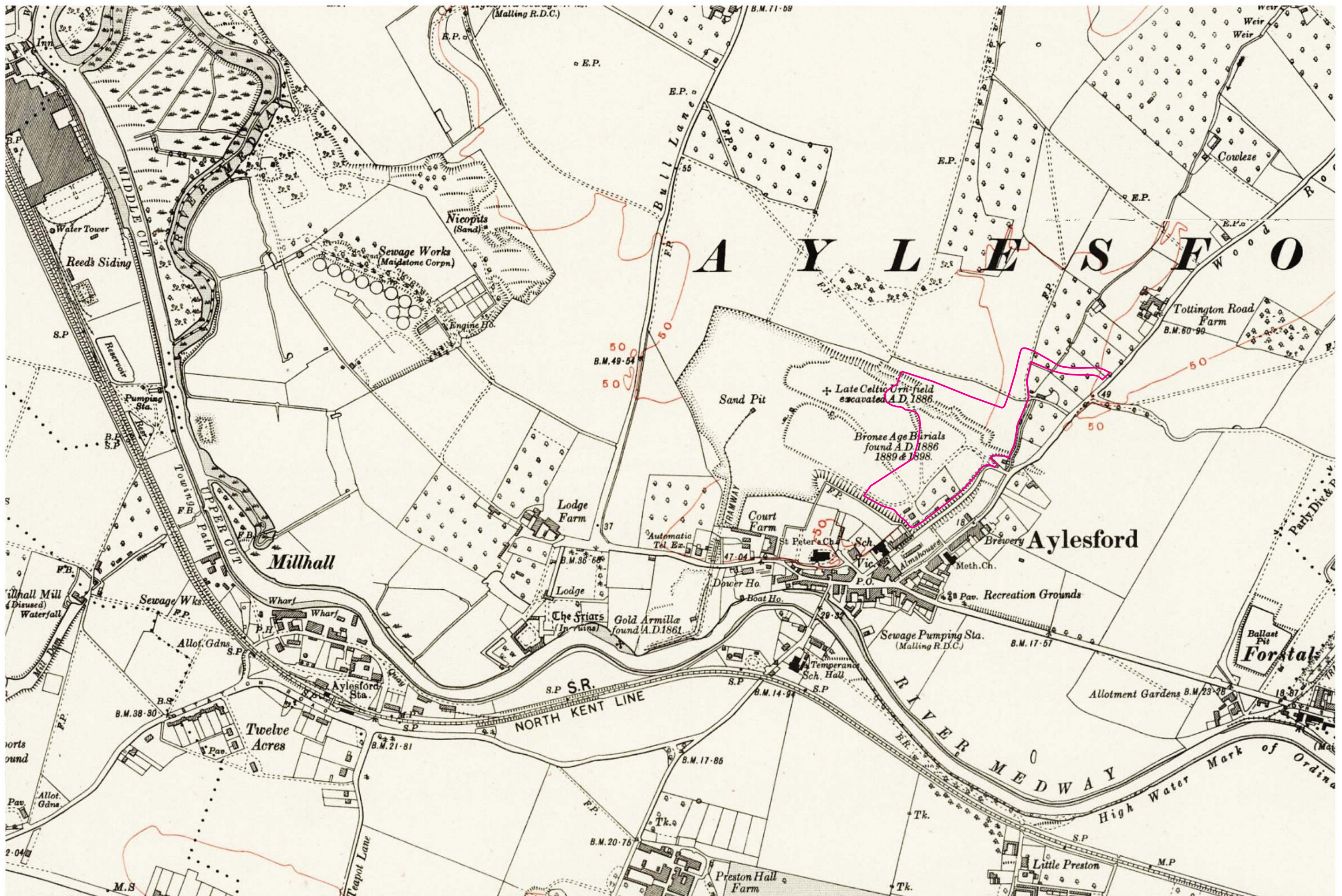

Figure 10: OS map from 1931, scale 1:6666



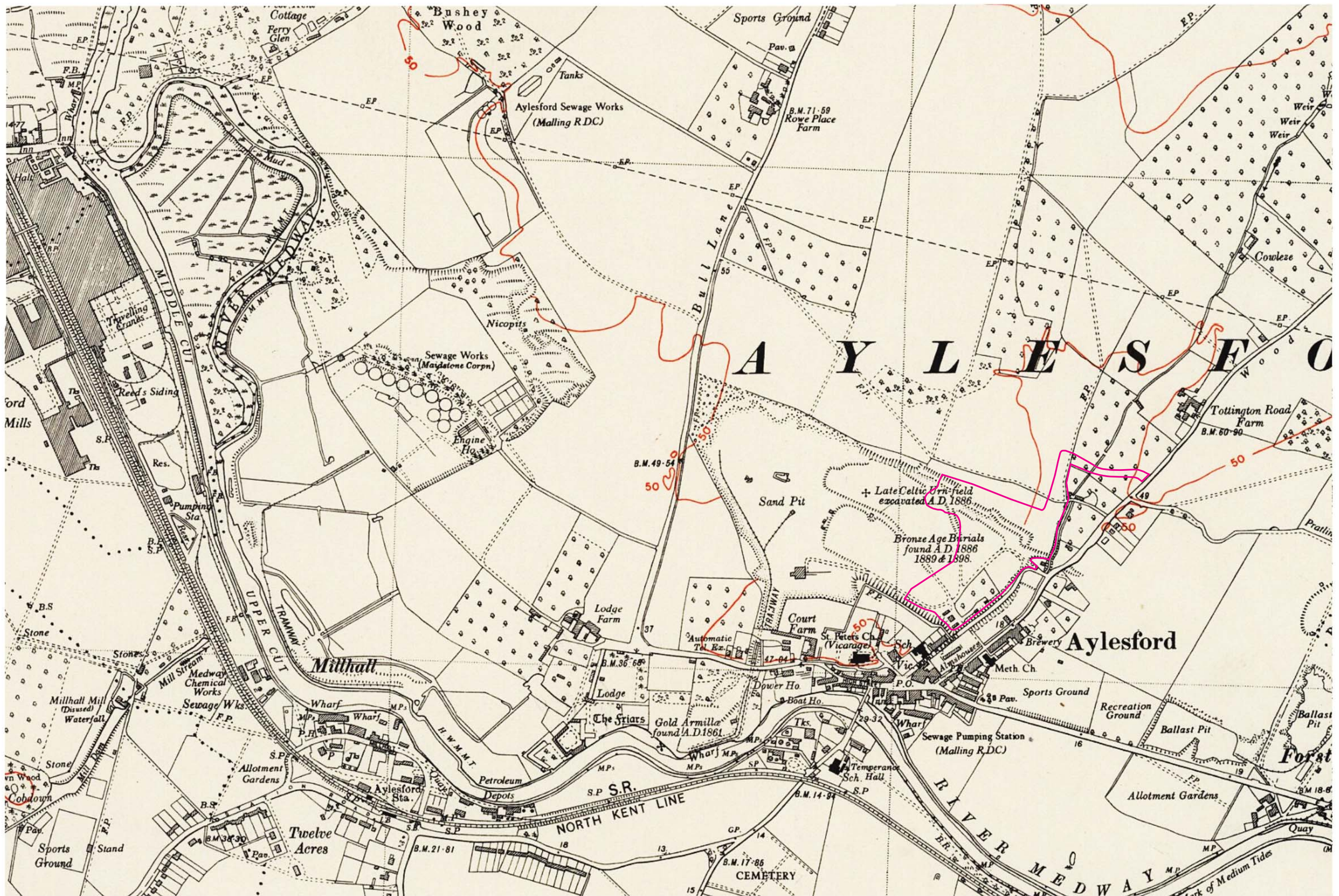

Figure 11: OS map from 1948, scale 1:6666



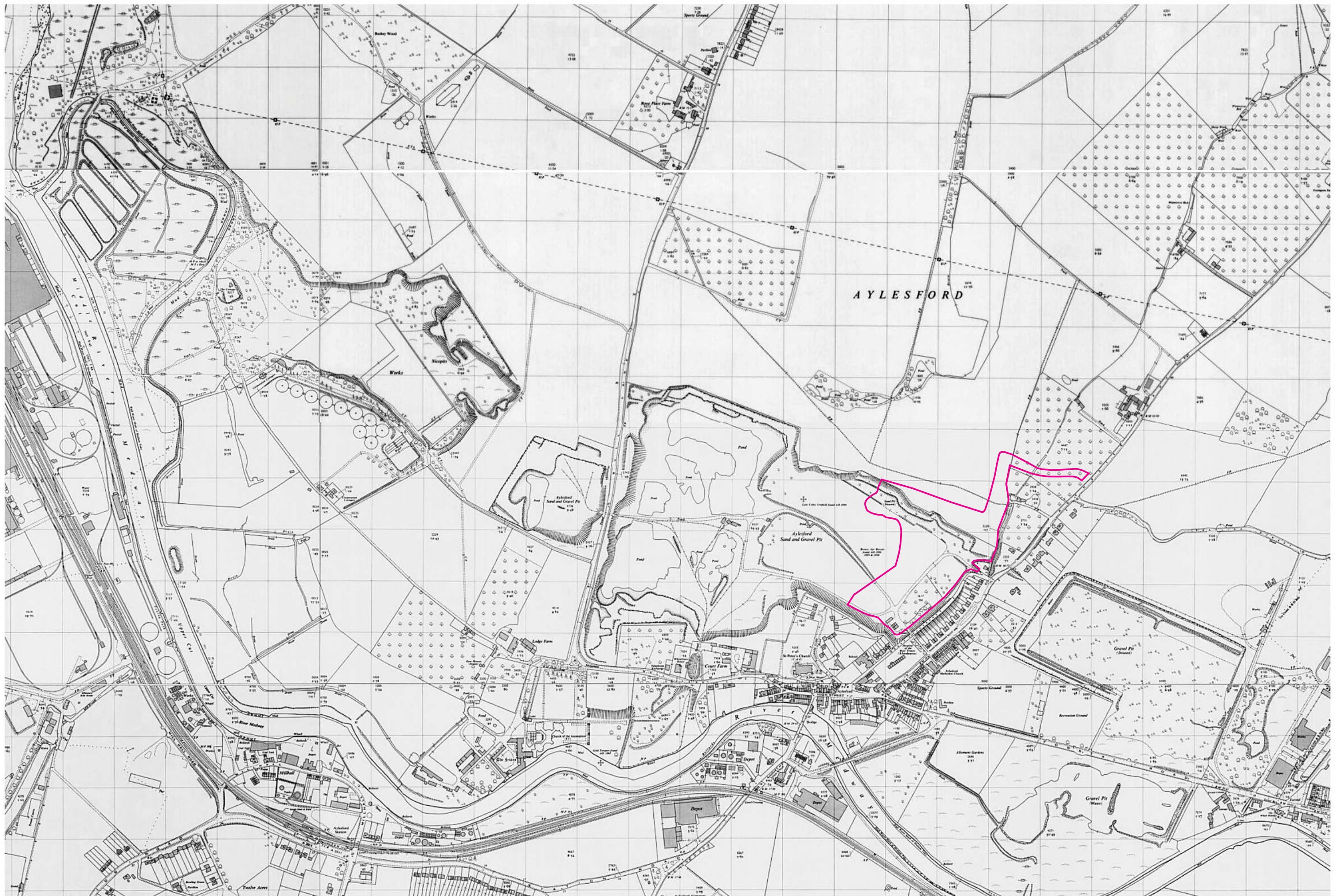
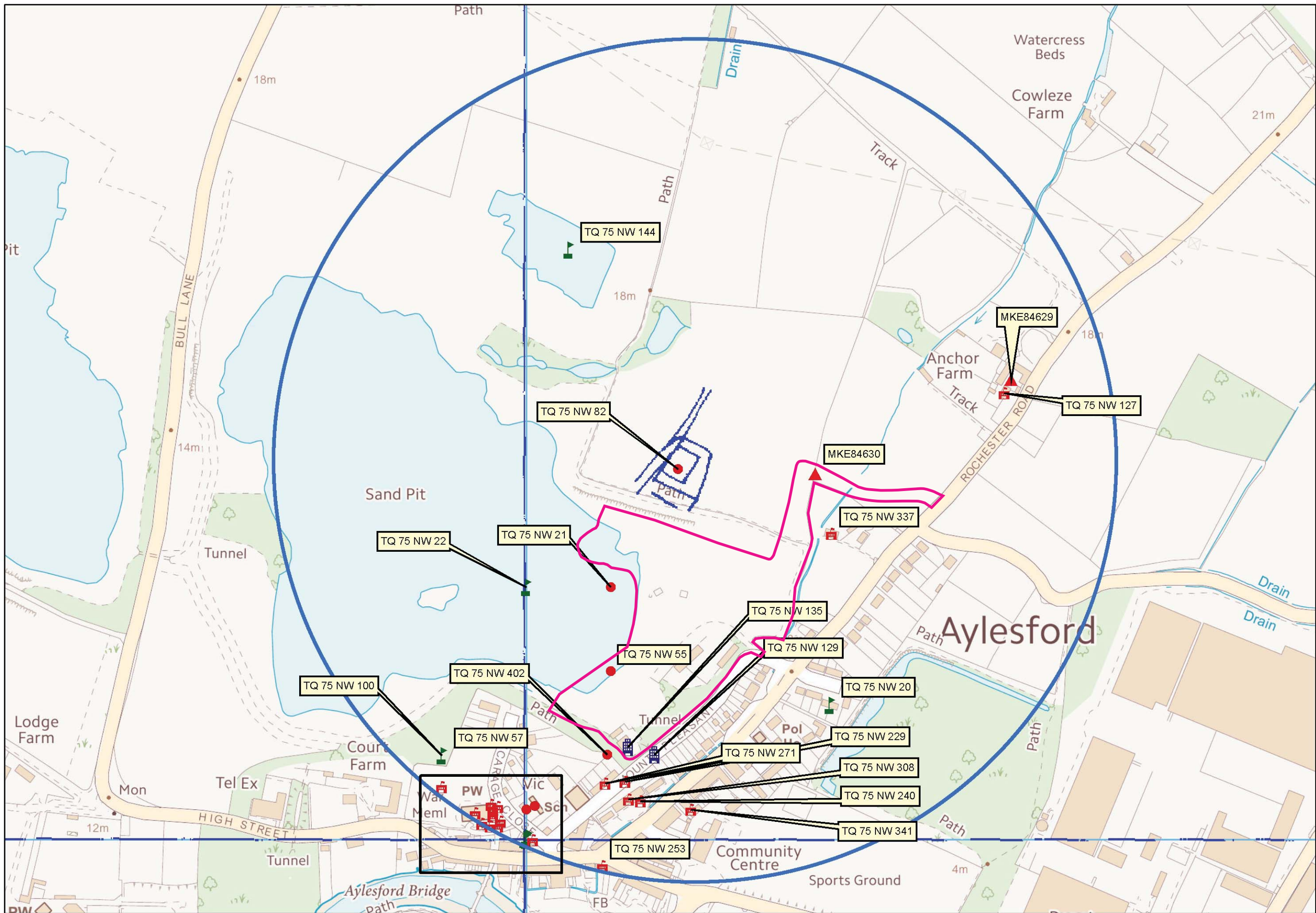

Figure 12: OS map from 1961, scale 1:6666



# Kent Historic Environment Record - Aylesford Quarries - Monuments and Cropmarks 1



- Legend**
- Building
  - Crash Site
  - Farmstead
  - Findspot
  - Listed Building
  - Landscape
  - Maritime
  - Monument
  - Place
  - HEDGE
  - MON
  - Mon (poly)





# Kent Historic Environment Record - Aylesford Quarries - Monuments 2

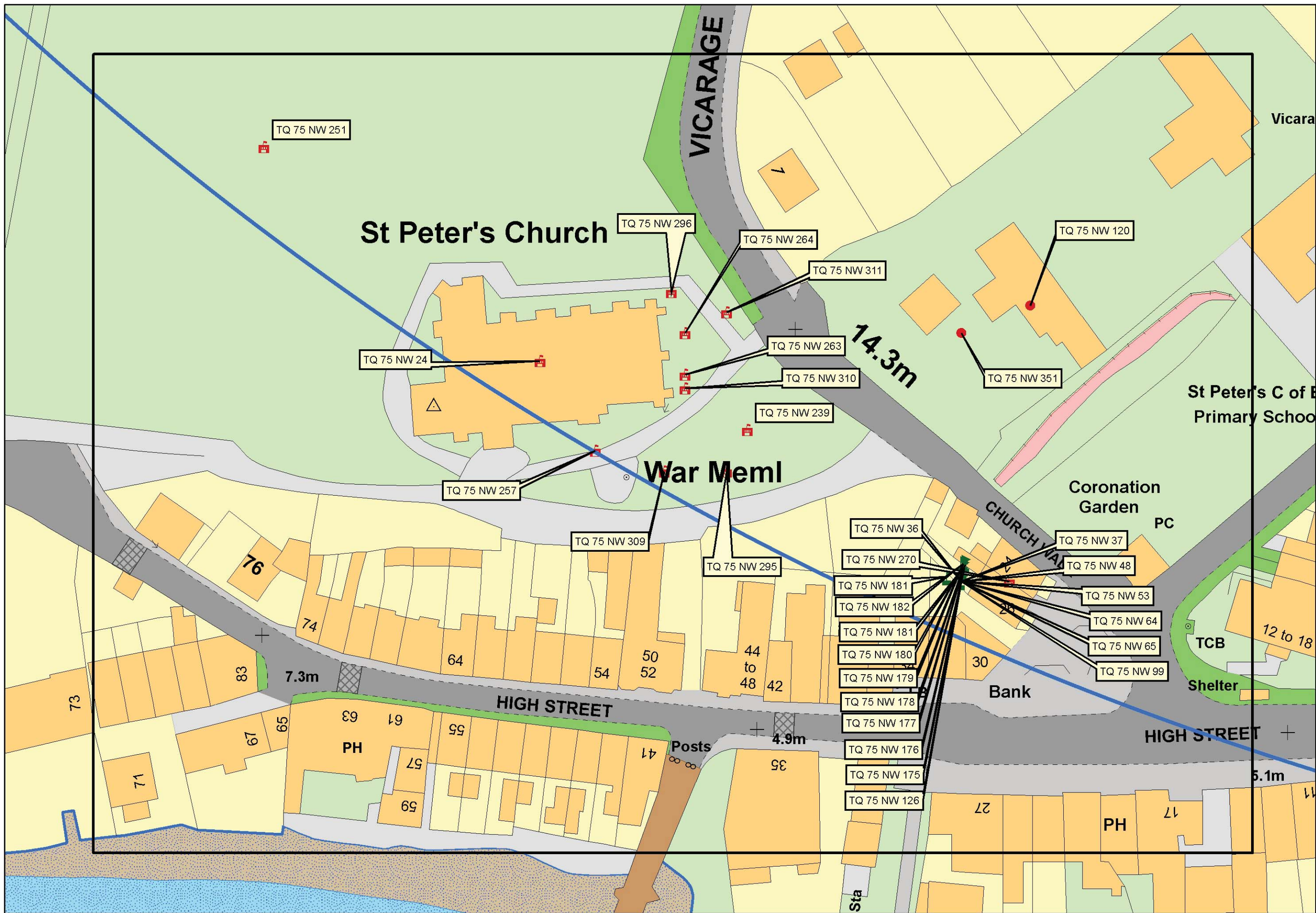

- Legend**
- Building
  - Crash Site
  - Farmstead
  - Findspot
  - Landscape
  - Maritime
  - Monument
  - Place
  - HEDGE
  - MON
  - Mon (poly)





# Kent Historic Environment Record - Aylesford Quarries - Conservation Areas



Legend  
Converted\_Graphics

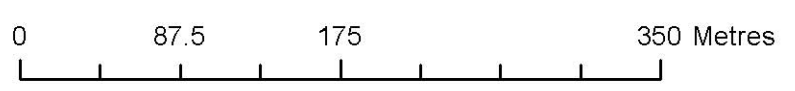



# Kent Historic Environment Record - Aylesford Quarries - Events



Legend  
 Converted\_Graphics









# Kent Historic Environment Record - MVPP zones

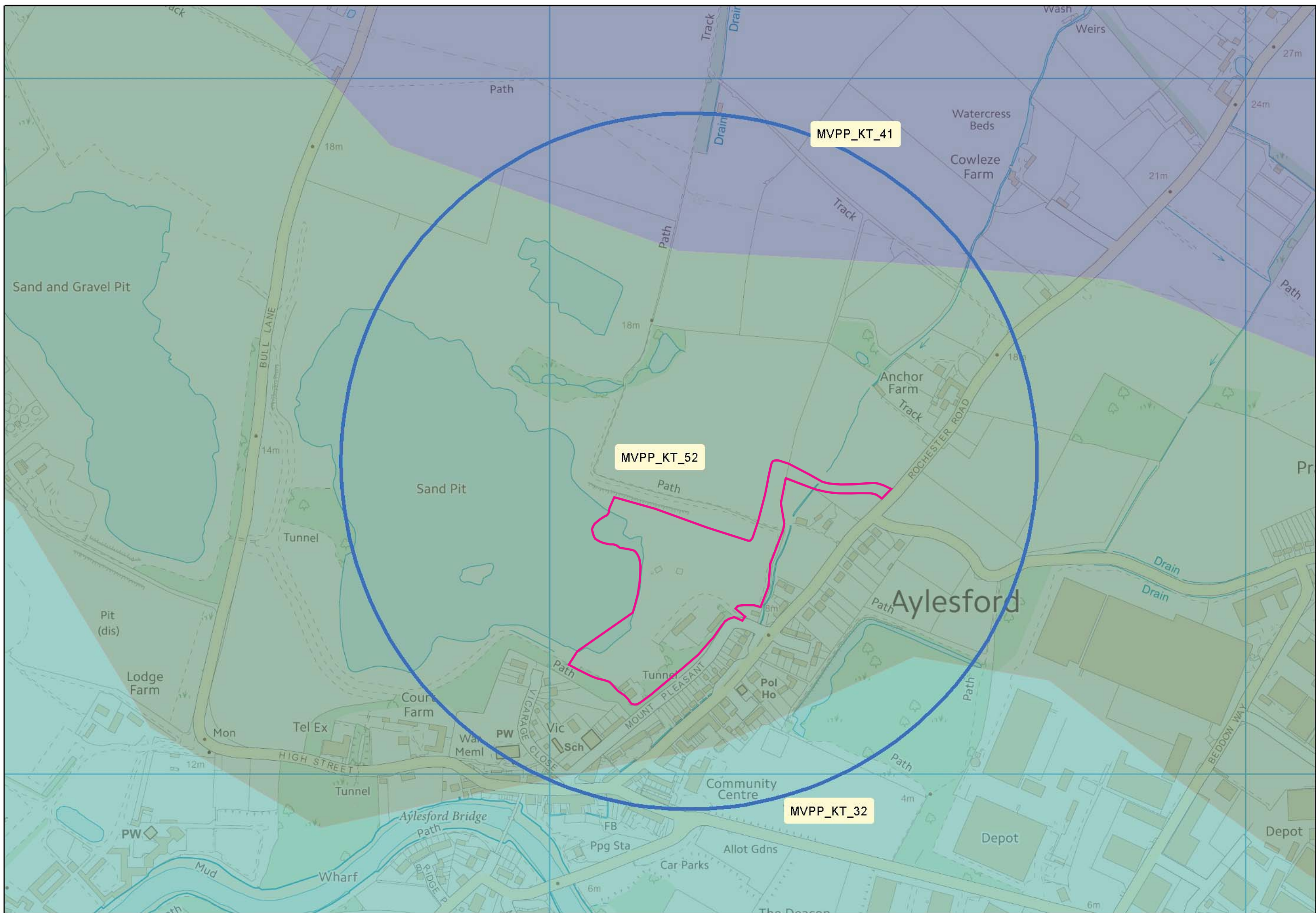

Legend  
Converted\_Graphics





# Kent Historic Environment Record - Reports

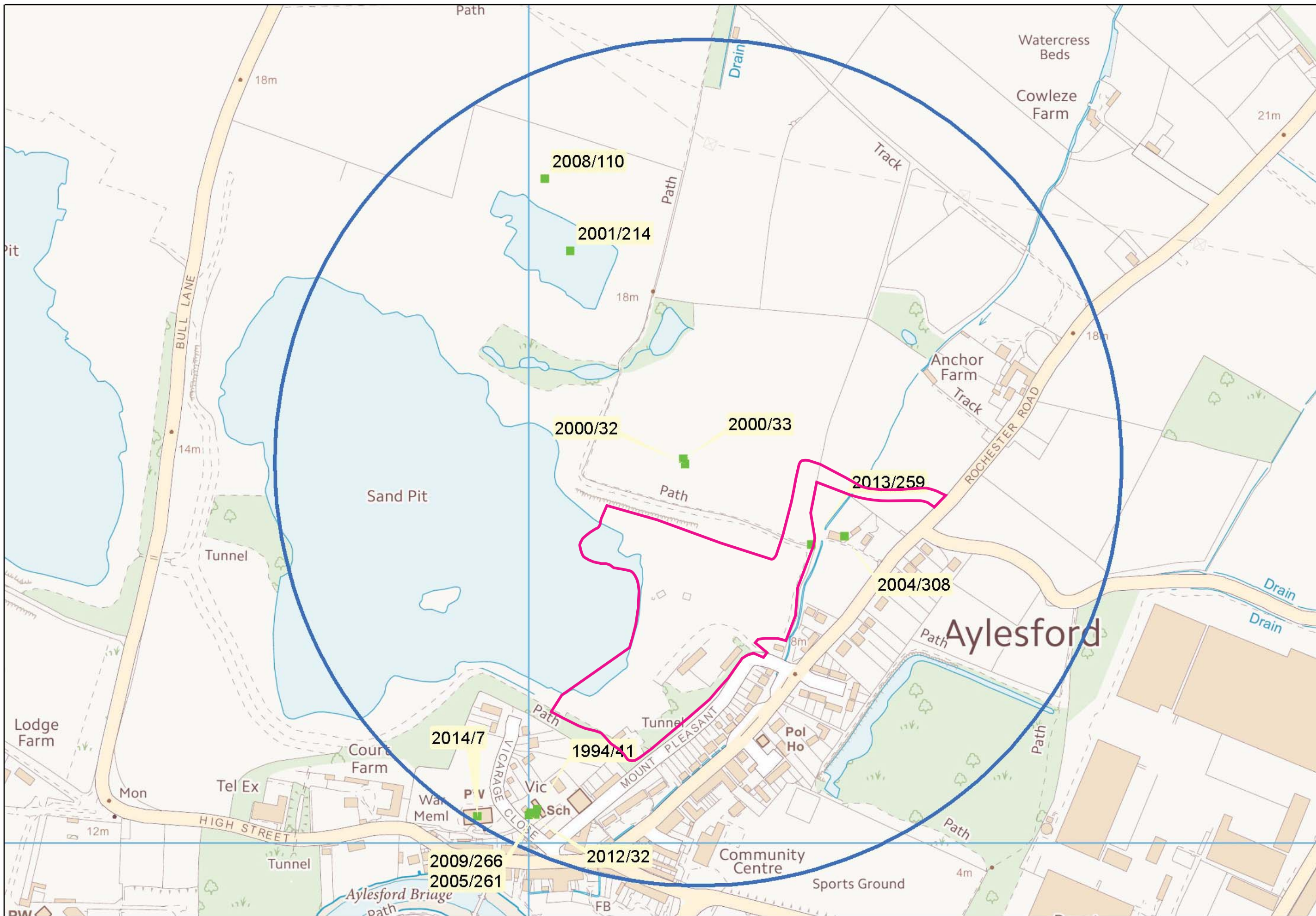

Legend  
 Converted\_Graphics

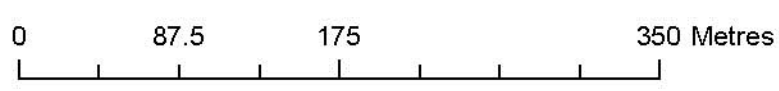



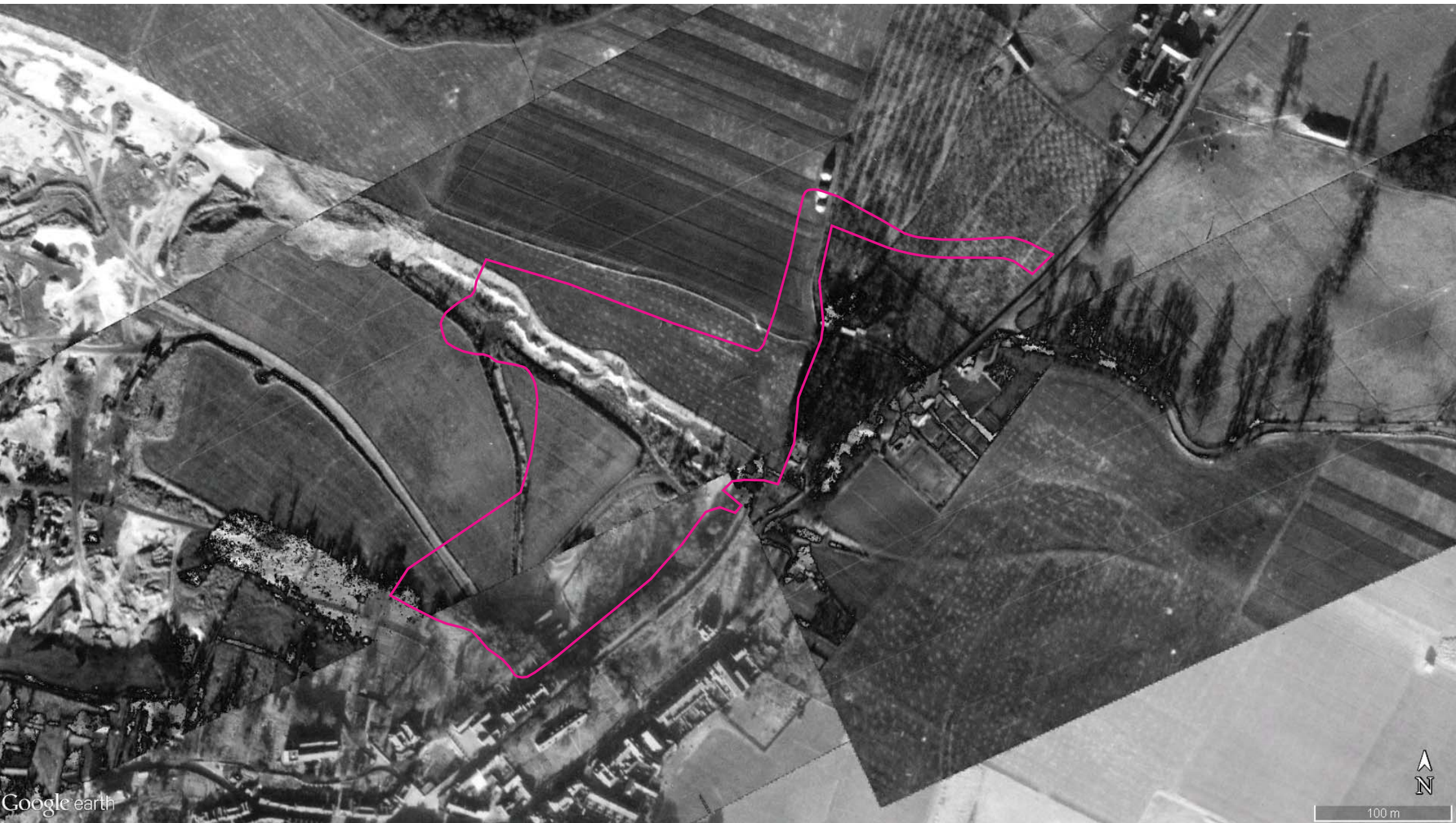

Plate 1: Google Earth aerial photograph from 1940.





Plate 2: Google Earth aerial photograph from 1960.





Plate 3: Google Earth aerial photograph from 1990.





Plate 4: Google Earth aerial photograph from 2007





Plate 5: Google Earth aerial photograph from 2013.





Plate 6: Google Earth aerial photograph from 2015.

**Archaeological Evaluation  
Tottington Farm  
Aylesford  
Maidstone, Kent  
TQ 7320 5945**

**Compiled by: Paul Hutchings BA, MA,  
PIFA,  
February 1999**

**For the clients**

---

**RMC Aggregates Southern  
RMC House  
The Square  
Lightwater  
Surrey  
GU18 5SS  
Tel.01276 456600**

*CANTERBURY ARCHAEOLOGICAL TRUST  
92a BROAD STREET  
CANTERBURY  
KENT CT1 2LU*

**Archaeological Evaluation  
Tottington Farm  
Aylesford  
Maidstone  
Kent  
TQ 7320 5945**

Compiled by: Paul Hutchings BA, MA, PIFA.  
February 1999

Prepared by:	<i>Paul Hutchings</i>
Date:	30/4/99
Checked by:	<i>M. Houlton</i>
Date:	14.09
Approved by:	<i>Mark Houlton</i>
Position:	<i>Field Officer</i>
Date:	7/4/99

Canterbury Archaeological Trust  
92 A Broad Street  
Canterbury  
Kent CT1 2LU

## CONTENTS

	<b>Page no.</b>
Acknowledgements	4
Topographical and Geographical Background	4
Archaeological Background	4
Methodology	5
Objectives and Aims	5
Confidence Rating	5
Results	6
Conclusions	11
Bibliography	13
Appendix 1	14
Illustrations	

## **ACKNOWLEDGEMENTS**

The Canterbury Archaeological Trust would like to thank Nigel Gould of RMC Aggregates (southern) limited for commissioning the work and for his co-operation, and Wendy Rogers of the Kent County Council Heritage Conservation Group for her assistance on the site.

## **TOPOGRAPHICAL AND GEOGRAPHICAL BACKGROUND**

The site is positioned on a hill just to the north of Aylesford Kent (TQ 7320 5945) at a height of *c.* 20.26 m OD. The site occupies land which falls gently from west to east; the land to the north of the site falls away sharply, and the field to the south has been excavated away for gravel extraction. To the west there is a dip in the land which contains a small area of woodland, and to the east lies the Rochester Road which runs north-east to south-west. The natural ground is shown on the Geological Survey of Great Britain (England and Wales) Solid and Drift, Sheet 288, as Folkestone Beds sand. The accompanying memoir (Worssam 1963, 52) records a 22 ft exposure of sand overlain by an 18 ft thickness of 2<sup>nd</sup> Terrace river gravel in a gravel pit just north of Aylesford (and adjacent to the site).

## **ARCHAEOLOGICAL BACKGROUND**

The Medway valley contains a dense concentration of archaeological sites dating from the Neolithic to the present day and in particular there is a large number of high status Roman sites (see Fig. A). The site is centred in an area rich in archaeology; several archaeological excavations have taken place in the near vicinity and a number of Roman sites have been found.

The area contains a cropmark enclosure (SMR NO: TQ 75 NW 82), and a Bronze Age burial site is recorded nearby to the south (SMR NO: TQ 75 NW 55). The latter included a cinerary urn and several crouched inhumations. An Iron Age burial site (SMR NO: TQ 75 NW 21) is located 150m to the south consisting of several cremations with first-century BC pottery. Several prehistoric flints have been recorded nearby including a palaeolithic hand axe and other implements (SMR NO: TQ 75 NW 56).

Prior to the evaluation a geophysical survey was carried out for Hall Aggregates by The Clark Laboratory of the Museum of London Archaeological Service (Bartlett 1998). The survey identified the previously recorded cropmark enclosure, and a second smaller enclosure to the north-west of the main enclosure. Other anomalies of unknown function were also detected.



## **METHODOLOGY**

Following the geophysical survey, trenches were mechanically excavated according to a pattern agreed with the county archaeologist and according to the specifications laid out by the Kent County Council Planning Department Heritage Conservation Group (Heritage Conservation Group, 1998). The trenches were excavated using a 360° mechanical excavator with flat-bladed ditching bucket. Six trenches were originally cut, following which it was decided that one needed to be extended and another further trench excavated in order to establish the orientation of archaeology exposed in the original six (Figure 1). Site machining, excavation and recording were carried out according to the specifications and the significant archaeology seen and discussed with Wendy Rogers of the Kent County Council Heritage Conservation Group.

## **OBJECTIVES AND AIMS**

The objectives and aims were set out in the specification (Heritage Conservation Group, 1998: Sections 3 to 4.1). Briefly the objectives were to determine the date and character of the features observed by the geophysical survey and to assess the importance of any archaeological levels discovered. The aims were to determine the extent, quality, character, date, depth below ground surface, and depth of deposit, of all archaeological remains uncovered during the work.

## **CONFIDENCE RATING**

Though the evaluation did not ascertain the full extent of the archaeological levels observed, it did provide sufficient information to achieve each of the other objectives outlined above. It was difficult to determine the precise extent of the archaeology due to the constraints imposed 'keyhole archaeology'. When working under these confines it is possible to miss important archaeological features and be misled. Although the trenches identified at least one area of concentrated archaeology, it is possible that further areas of important archaeology survive nearby which were not detected by the present work.

## RESULTS (Figure 1)

### Trench 1

Trench 1 was 15m long and located towards the south-east corner of the field. It was excavated to a depth of 0.48m. It was machined to the natural, which was a dull orange silty sandy clay with gravel. Above this was an interface layer, between 0.10m and 0.11m thick, made up of the ploughsoil and the disturbed upper natural. The ploughsoil was 0.12m thick at the north-west end of the trench and 0.22m thick at the south-east end, and was a pinkish, red-brown, slightly clayey, silt. The topsoil was c.0.25m thick and contained less clay than the ploughsoil.

### Trench 2 (Figure 2)

This trench was located to the very south of the field; it was 20m long and cut to a depth of c.0.60m. Cut into the natural was a number of features. In the west of the trench was a rectilinear feature [cut 19] 1.40m wide; it was truncated by the north section. It was not fully excavated as the material found in the fill (18) contained modern tile and pottery. Towards the west of the trench was a large pit [8] which was 1.40m wide and truncated by the north section. It measured 0.40m deep and had steep sloping sides and an undulating base. The fill was dark grey brown sandy silt with occasional pottery and bone. It is thought that this is a Roman pit although only part of the feature was seen.

Further to the west was a linear feature orientated north to south running across the trench. The cut [13] was up to 0.56m wide and very shallow at only 0.08m deep. The fill was dark brown sandy silt with frequent small to medium flints. This feature is probably a shallow gully, but it is difficult to determine its date as no finds were recovered or seen. Its proximity to cut [8] and the shape of its profile suggests that it may be of the same date.

Just to the south-west of [8] and truncated by the south section was a large almost square feature [1]; it was 1.70m wide. It was not fully excavated as the fill [2] contained modern pottery and scrap metal.

No other features were seen after cleaning this trench. Capping the fills of the above-described features was a ploughsoil [23] consisting of a pinkish red-brown clay-silt up to 0.48m thick. Overlying this was a layer of topsoil up to 0.23m thick.

### **Trench 3**

This 10m long trench was located in the south-west corner of the field. It was machined down to the natural, which was recorded at a depth of 0.70m in the east and 0.46m in the west.

No features were recorded in this trench.

Just above the natural was an interface layer, between 0.05m and 0.10m thick, of disturbed natural. Above this the ploughsoil was between 0.23m and 0.35m thick. The topsoil was 0.16m thick in the east and 0.25m thick in the west and this capped the entire trench.

### **Trench 4 (Figure 3)**

This trench was 20m long and positioned to the north centre of the field and orientated north-west to south-east. The trench was machined down to the natural subsoil, a depth of 0.43m in the south-east and 0.64 in the north-west.

In this trench two features were seen cutting the natural. Towards the south-east of the trench a narrow linear feature [16] 0.12m to 0.22m wide, and between 0.02 and 0.05m deep, was excavated. Because this was all that survived the true nature of the sides was unclear, but it was possible to determine that the base was slightly concave. The feature also appears to have been located in trench 7, and is interpreted as a gully. The fill (17) contained no finds and had many similarities to the overlying plough soil but was slightly lighter and sandier.

Just to the north-west of the feature described above was a substantial linear cut, which ran across the trench north-north-east to south-south-west. The cut [9] was 1.80m wide and 0.70m deep; on the northernmost edge the cut was shallow at the top and, at a point half way down, broke sharply and sloped steeply (see figure 3). This may have represented a later re-cut. The feature is interpreted as a ditch. It contained three fills. The primary fill (12) was redeposited natural and contained pottery sherds. It is possible that this represents the collapsed sides of the feature, or was caused by the spoil created from digging the ditch falling back in. Above this was a dark grey sandy silt (11) with frequent charcoal fragments which also contained pottery fragments. Capping the ditch was a mid to dark brown, sandy, silt-clay which contained frequent pottery sherds. This was 0.30m deep and may represent the fill of a possible shallow re-cut to the ditch. This feature appeared to continue in a south-south-west direction and was possibly identified in trench 7.

Both the above features were cut by a ploughsoil and then a topsoil similar to those seen in the other trenches. No other features were seen in this trench.



## Trench 5 (Figures 4 and 5)

Trench 5 was situated slightly to the north-west of the centre of the evaluation area and orientated north-west to south-east. It was 20m long, later extended to 22m to incorporate a feature truncated by the south-east short section. The trench proved to contain the majority of the archaeological features located during the evaluation, these consisting largely of linear ditches.

In the furthest north-west part of the trench a linear feature [6] 0.88m wide and 0.17m deep was seen cutting across the trench north to south. This shallow ditch or gully contained a single fill (5) of red brown clay silt with occasional flint nodules and sandstone. No finds were retrieved.

Just to the south-east was a large feature which excavation proved to be several inter-cutting features probably all backfilled at the much the same time (see figure). Three ditches were identified ([66], [65] and [64]). Cut [66] was shallow at 0.28m deep and 1.40m wide. Cut [65] to the south-east was 1m wide and 0.43m deep and may well have been later than [66]. Cut [64] to the south-east of [65] was deeper at 0.62m and wider at 1.60m. The fills of all of the ditches were fairly uniform consisting of a mid to dark brown clay silt containing sherds of pottery, but could be distinguished one from another by the quantity of flint, stone and gravel inclusions. The fill to [66] was recorded as (60) and included a collection of sand and flint stones towards its north-western limit. There was not enough however to make up a metalled surface although the shape and depth of this feature may represent a hollow way. Deposit (59), which was the fill to cut [65] was similar to (60) but contained more scattered and frequent small round and sub-round flint and gravel. Deposit (22) seen in [64] contained medium to large round and sub-round sandstone fragments and flint nodules. The sequence in which the ditches were cut could not be determined as their fills were so similar. It is, therefore, likely that they were cut at much the same time; they may well have been open together and backfilled together.

Deposit (22) was truncated to the north-east by cut [63] which was 1.60m wide and 0.53m deep and appeared to run right across the trench. It was filled by (21), a dark brown, almost black, sandy silt with small to large sand and flint nodules and pottery sherds. This is interpreted as a ditch.

Ditch [63], which was also located in the north-east, contained two deposits. The earliest of these (52) consisted of a mix of greeny, cream-coloured, decayed chalk and sand, with frequent chalk fragments; the sand became finer towards the base. The deposit was 1.60m wide and 0.40m deep and is tentatively interpreted as decayed, *opus signinum* mortar by its colour and sand and chalk content. This was probably a dump deposit. It was also truncated to the north-east by a probable linear ditch cut [4], 1.10m wide, and 0.27m deep. Its side sloped steeply in the north-east and gradually in the south-west, and it had a flat base. It contained two fills: (62) and (3). The first of the fills (62) was a green brown mix of fine and coarse sand and brown silt with no inclusions. The secondary fill (3) was a mid brown sandy silt with occasional pea-sized stones and chalk flecks. This did not fully cap the ditch and may represent a shallow re-cut of the original ditch. This and (52) were overlain by a possible dump

deposit of orange red sand mixed with silt (61 with no inclusions. It was cut by (64) to the south-west.

Two features were also seen in this area. Cut [68], to the very south-west, was 0.09m wide and 0.09m deep. Another, [67], was 0.15m in diameter and 0.12m deep. These may represent stake-holes, but could equally be the result of root action.

In the south-east of the trench a number of intercutting ditches similar to those described above was also recorded. These too were seen running directly across the trench. The earliest of these ditches, [57], was an irregular, 'V' shape in section, was 1.40m wide and 0.50m deep. It contained a number of fills. Primary fill (55) was a medium grey, sandy, silt with a minimum clay content containing moderate quantities of small flint fragments. Completely capping this was a deep, 0.42m thick, fill (69) of moderate to dark grey brown sandy silt with occasional flint fragments and charcoal. This appears to have had a further two fills overlying it. These were (51), a layer of pinkish light grey mortar possibly *opus signinum* and (54), a dump of medium-sized stones set in mortar. Both these deposits were truncated to the south-east by [53] a shallow scoop 0.10m deep and 1.20m wide. This may have been truncated through plough action. It contained a single fill of dark grey brown silt with fragments of yellow mortar and charcoal and appeared spread to the south-west through plough action.

Fill (54) was also truncated to the north-west by a linear cut [58] which was 1.40m wide and 0.44m deep; it was sloped steeply in the south-east and at very shallow gradient in the north-west. This is interpreted as a shallow ditch or gully, eroded or ploughed away in the north-west. The fill (56) was a mid dark brown sandy silt with occasional stone inclusions, which was sandier towards the base. This was cut to the north-west by [45] a probable linear ditch cut 0.80m deep which was 'V' shaped in section and contained a fill (46) of mid, grey brown, sandy, silt, mixed with occasional charcoal, pot and animal bone. It was truncated to the north-west by [44] a large ditch, 1.70m wide and 0.74m deep, which was more bowl-shaped in section with uniform, gradual sloping, sides. This feature contained a fill (20) comprised of mid to dark grey brown sandy silt with moderate charcoal flecks, tile fragments, and frequent pottery sherds. The feature was also truncated by a ditch to the north-west [47] which may also have been bowl-shaped prior to its truncation, with a relatively steep slope on its north-western side. It contained a fill (48) of medium brown sandy silt with frequent small gritty flints, occasional pottery and large tile fragments.

Overlying the entire trench was a ploughsoil up to 0.24m thick and a topsoil up to 0.28m thick.

### **Trench 6 (Figure 6)**

This trench was located to the very north-west of the evaluation area and was aligned north-west to south-east; it was 0.15m long. It was cut to a depth of 0.63m in the north-west and 0.65m in the south-east.

Archaeological features were located in the south-east half of this trench. The earliest was a linear cut [42], which ran across the trench in an almost north to south direction and was 0.22m deep and 1.08m wide. It was deep and concave in section and contained a fill (43) of dark brown, sandy silt mixed with occasional prehistoric pot and frequent small rounded flints. This feature is interpreted as a backfilled ditch.

Truncating the above fill (43) was the most substantial of the features located in this trench, a large cut [25] which ran south-west from the northernmost section and then changed direction at almost a right angle. It was 1.35m wide and 0.43m deep and appeared as an irregular 'V' shape ditch in section. This is thought to represent a possible enclosure ditch. The fill (26) was a dark grey almost black clay silt containing several pieces of prehistoric pottery and worked flint. The fill may have been truncated by ploughing as it seems to have spread beyond its south-eastern edge.

Further to the south-east was another linear cut [49] running north-east to south-west. This was a shallow concave gully 0.86m wide and 0.16m deep. It was filled by a dark brown silty sand (50). This feature may have been heavily truncated by ploughing.

The only other features in this trench were natural. Overlying the features was a ploughsoil up to 0.46m deep and topsoil up to 0.22m deep.

### **Trench 7 (Figure 7)**

This was an additional trench positioned between trenches 2 and 4 in order to locate the direction and extent of those features seen in trench 4. It was 17.5m long.

The trench exposed a number of features including the probable continuation of features [9] and [16] in trench 4. A linear cut [36], 0.30m wide and 0.10m deep with a concave base and steep sloping sides, was seen running across the trench. The fill (37) was mid brown sandy silt with occasional prehistoric pottery. This was very similar to [16] in trench 4 and is thought to be the continuation of it. A 1.60m. wide linear cut [38] may be a continuation of [9] in trench 4. It was filled by (39), a mid to light sandy silt with occasional charcoal and pottery, similar to (10) in trench 4.

Fill (39) was truncated to the north-east by a cut [40], and by the north-east section; it appeared sub square in plan measuring 1.20m by 0.90m, and although not excavated is thought to be a partially exposed pit. The fill (41) was a mid brown sandy silt with frequent charcoal flecks.

Further to the south-east, and partially exposed along the northernmost side of the trench, was a square shaped feature [34]. It measured 0.62m by 0.62m and was filled by (35) a mid brown sandy silt mixed with very frequent flint nodules, a large stone



block in excess of 0.42m, pottery sherds and charcoal fragments. It was not excavated, but is assumed to be a pit.

Another thin linear gully [32] was recorded to the south-east of the above pit. It ran directly across the trench and measured between 0.09 and 0.20m wide. It was filled by (33) a mid brown sandy silt with occasional charcoal fragments. A Roman coin found on the surface of this feature during cleaning has been identified as Claudian (AD 45 to 65).

Just to the south-east of the above gully was a sub circular feature [30] with a diameter of 0.50m, a depth of 0.12m and a flat base. The fill (31) consisted of mid brown, sandy silt. The feature is thought to be the remains of a shallow pit.

Partially seen next to the northernmost section was [28] a sub circular shallow cut 0.95m wide and 0.12m deep. Its fill (29) was mid to light, grey-brown, sandy silt mixed with very occasional charcoal flecks. This is thought to be another shallow pit.

A ploughsoil and topsoil also covered this trench. No other features were seen cut into the sections or natural.

## CONCLUSIONS

A number of substantial features were located during this evaluation, some of which had already been highlighted by the geophysical survey.

Trenches 1 and 3 contained no archaeological features. The archaeology found in the remaining trenches largely consisted of pits and ditches. These are thought date from the Late pre-Roman Iron Age and the early Roman period (mid first century BC to mid to late first century AD), though some features may be of prehistoric origin.

The presence of *opus signinum* within trench 5, the ridge tile, and domestic waste material, would suggest settlement activity in the immediate area. The nature of the occupation cannot be determined at this stage as there is no physical evidence for any structures or building foundations. However, the presence of building material almost certainly means that there must have been some form of building located nearby.

A substantial number of features with datable fills were examined, many of which can be interpreted as enclosure ditches. A large number of these had been re-cut on several occasions, implying a certain longevity of use for the area.

It is likely that the archaeological features recorded during the evaluation are directly related or correspond to the features previously indicated by the aerial photographs and confirmed by the recent geophysical survey (Bartlett, 1998). These include cut [13] in trench 2, cut [9] in trench 4, many of the linear cuts in trench 5, cut [25] in trench 6 and cut [38] in trench 7 (thought to be the continuation of [9]). The evaluation has confirmed many of the findings of the geophysical survey.

It is therefore only reasonable to assume that there is significant archaeology within the evaluation field, although at this stage only the general nature and extent of it has been ascertained.

It is likely that there was once a farmstead on the present site, but as is typical of such sites the very soils that attracted the original farmers have also attracted deep ploughing and development in recent centuries, virtually obliterating most of the evidence. Detsicas (1983, 85) has discussed these farmsteads, and in particular their positions and functions within the local landscape. He states, 'the farmsteads were enclosed either by circular or rectilinear ditches, usually flat bottomed or with a V profile. Within these enclosures would be situated the dwelling hut, which was normally rounded and presumably not different in construction from Iron Age round huts.' The residents of such farmsteads were probably tenants, living and working within the grounds of the larger farms and villa estates. Although structural evidence was not recovered, associated archaeology such as rubbish pits and ditches similar to those discussed by Detsicas, were identified during the evaluation.

Less than 2 kilometres away to the north-west, at Rowe Place Farm, Eccles, lies the major villa estate of the Medway valley. Excavations undertaken between 1962-76 established the continued occupation of this villa-estate from the middle of the first century to the end of the Romano-British period. If the features found during the evaluation are those of a farmstead it may have been a tenant farm during the early life of the Eccles villa estate.

The presence of some prehistoric pottery on the site and the nature of the archaeology found in the vicinity (see SMR records mentioned above) makes it likely that the origins of the site lie in the Late Iron Age.

## BIBLIOGRAPHY.

- Bartlett, 1998                      Bartlett, A., *Tottington Farm, Aylesford, Kent, Report on Archaeological Survey, 1998*, The Clark Laboratory, MOLAS, 1998.
- Detsicas, 1983                      Detsicas, A., *The Cantiaci*, Alan Sutton, Gloucester, 1983.
- Heritage Conservation Group, 1998                      Heritage Conservation Group,  
*Specifications for Archaeological Evaluation of Land at Tottington Farm Quarry, Aylesford, Kent*, Kent County Council, 1998.
- Worssam, 1963                      Worssam, B.C., *Geology of the Country Around Maidstone, Memoir for 1:50,000 geological sheet 288 (England and Wales)*, British Geological Survey, HMSO London, 1963.



## APPENDIX 1

Trenches 1 and 3 contained no finds or features and as such only had trench record sheets filled out for them. Both trenches had the same geology of topsoil over plough soil over an interface between the plough soil and natural over the natural gravel.

### DESCRIPTION OF CONTEXTS TRENCH NUMBER 1

Context	Cut, Fill, Deposit	Type and Description
1	Cut	Modern pit
2	Deposit	Fill of 1
7	Deposit	Fill of 8
8	Cut	Pit
13	Cut	Ditch/Gully
14	Deposit	Fill of 13
18	Deposit	Fill of 19
19	Cut	Modern pit
23	Deposit	Plough soil
24	Deposit	Interface layer between ploughsoil and natural

### DESCRIPTION OF CONTEXTS TRENCH NUMBER 4

Context	Cut, Fill, Deposit	Type and Description
9	Cut	Ditch
10	Deposit	Fill of 9
11	Deposit	Fill of 9
12	Deposit	Fill of 9
16	Cut	Gully
17	Deposit	Fill of 16

DESCRIPTION OF CONTEXTS TRENCH NUMBER 5

Context	Cut, Fill, Deposit	Type and Description
3	Deposit	Fill of 4
4	Cut	Gully
5	Deposit	Fill of 6
6	Cut	Gully/Ditch
20	Deposit	Fill of 44
21	Deposit	Fill of 63
22	Deposit	Fill of 64
44	Cut	Ditch
45	Cut	Ditch
46	Deposit	Fill of 45
47	Cut	Ditch
48	Deposit	Fill of 47
51	Deposit	<i>Opus signinum</i>
51	Deposit	<i>Opus signinum</i>
53	Cut	Ditch
54	Deposit	Dump/layer
55	Deposit	Primary fill of 57
56	Deposit	Fill of 58
57	Cut	Ditch
58	Cut	Ditch
59	Deposit	Fill of 65
60	Deposit	Fill of 66
61	Deposit	Possible dump
62	Deposit	Fill of 4
63	Cut	Ditch
64	Cut	Ditch
65	Cut	Ditch
66	Cut	Shallow ditch?cut
67	Cut	Stake hole
68	Cut	Stake hole
69	Deposit	Secondary fill of 57

DESCRIPTION OF CONTEXTS TRENCH NUMBER 6

Context	Cut, Fill, Deposit	Type and Description
25	Cut	Enclosure ditch
26	Deposit	Fill of 25
42	Cut	Gully
43	Deposit	Fill of 42
49	Cut	Gully
50	Deposit	Fill of 49



DESCRIPTION OF CONTEXTS TRENCH NUMBER

Context	Cut, Fill, Deposit	Type and Description
28	Cut	Pit
29	Deposit	Fill of 28
30	Cut	Pit
31	Deposit	Fill of 30
32	Cut	Gully
33	Deposit	Fill of 32
34	Cut	Pit
35	Deposit	Fill of 34
36	Cut	Gully
37	Deposit	Fill of 36
38	Cut	Ditch
39	Deposit	Fill of 38
40	Cut	Pit
41	Deposit	Fill of 40

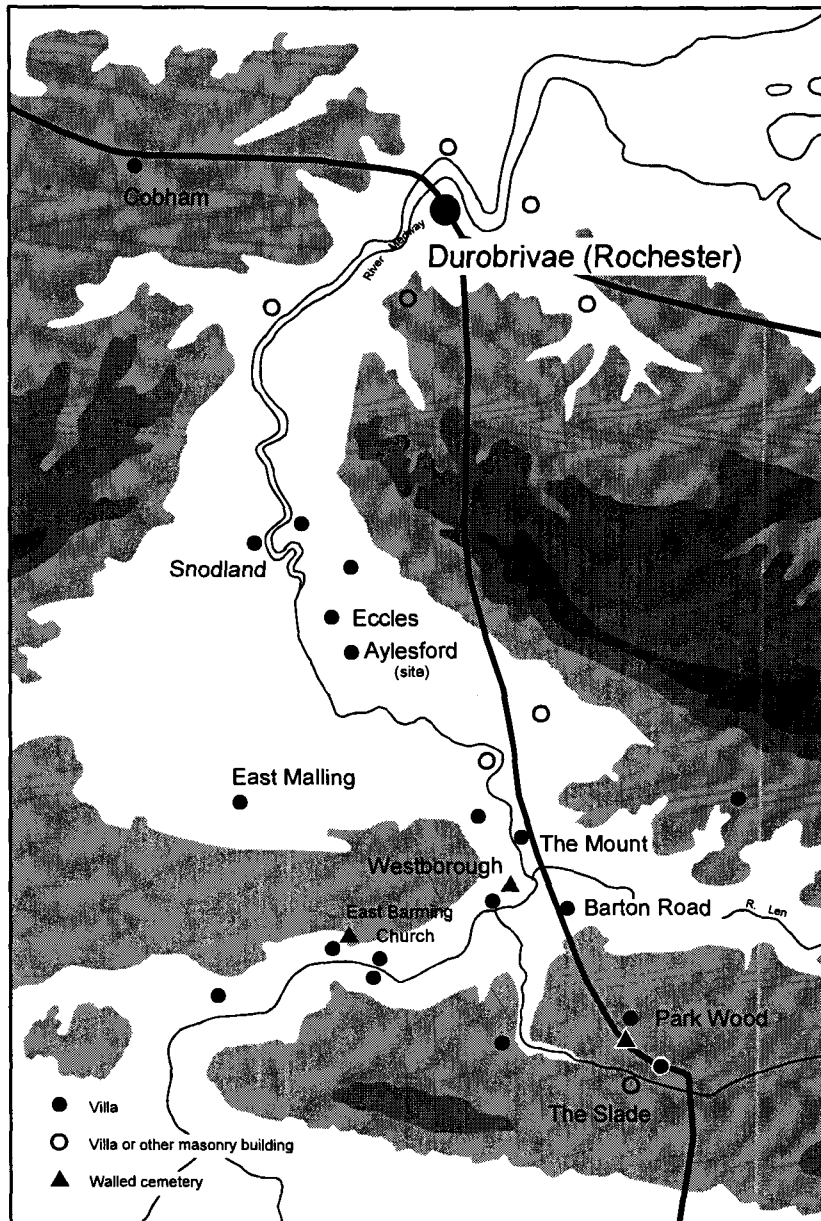
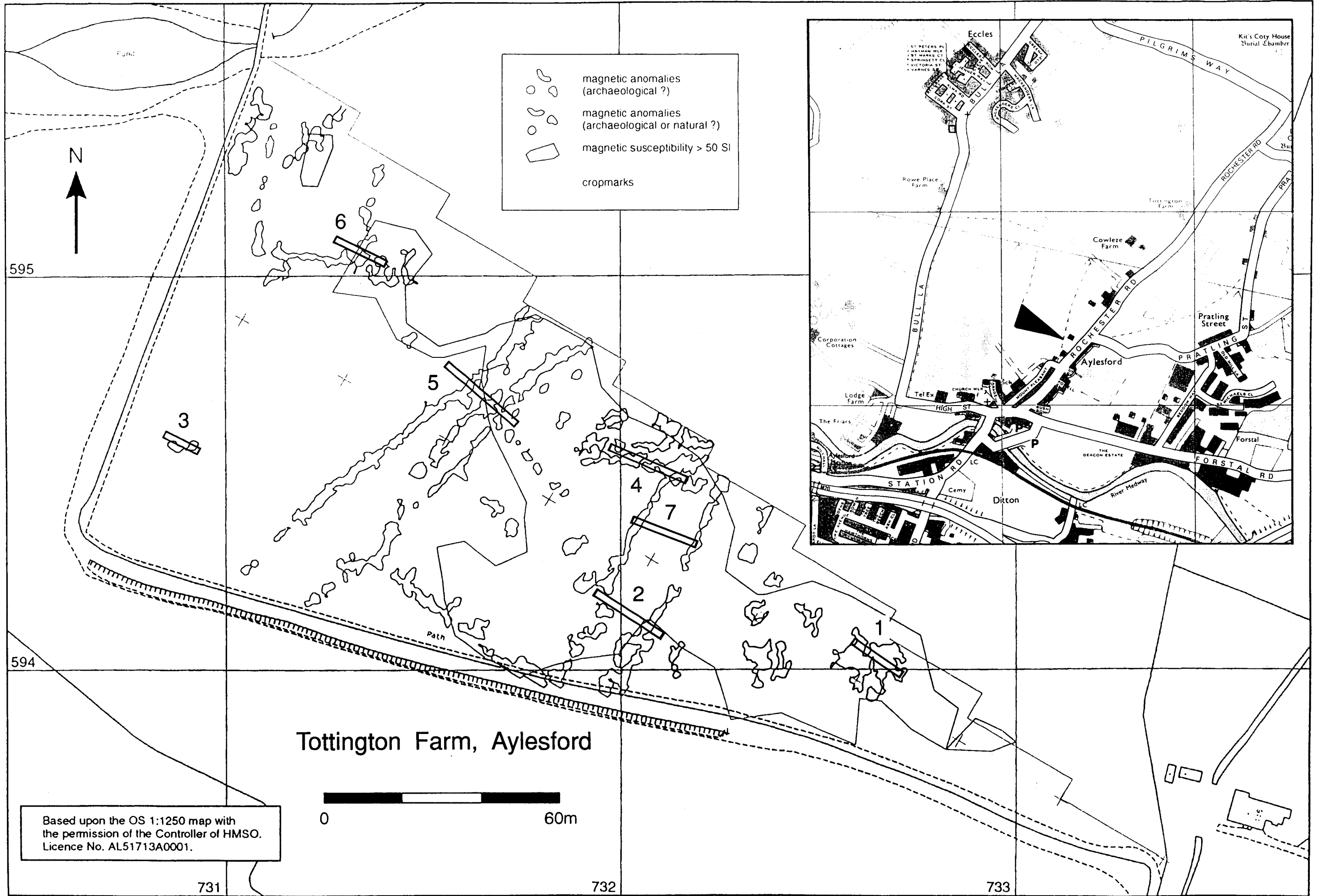

Fig. A: Principal Roman sites of the Medway area





Site code : TFA'99

Fig.1

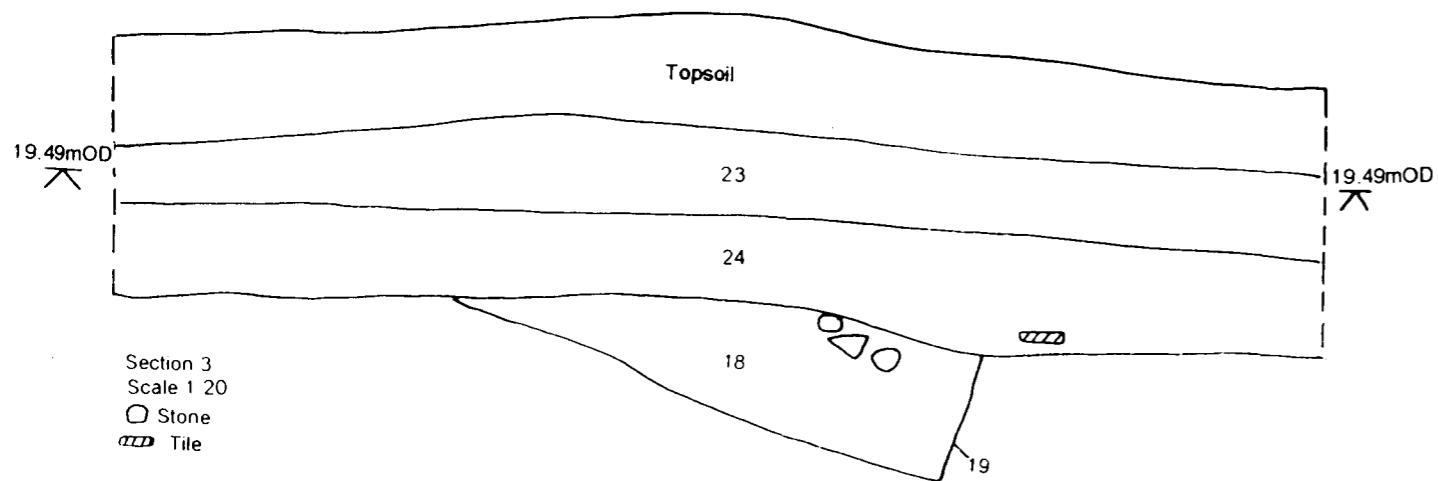
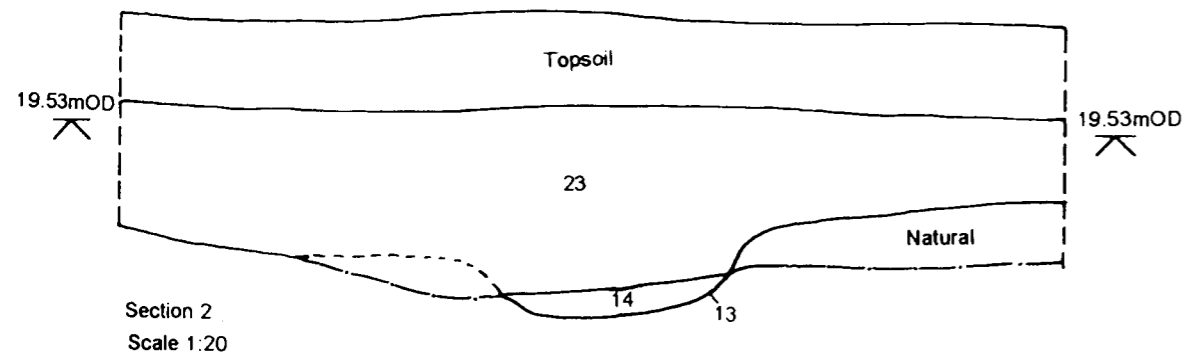
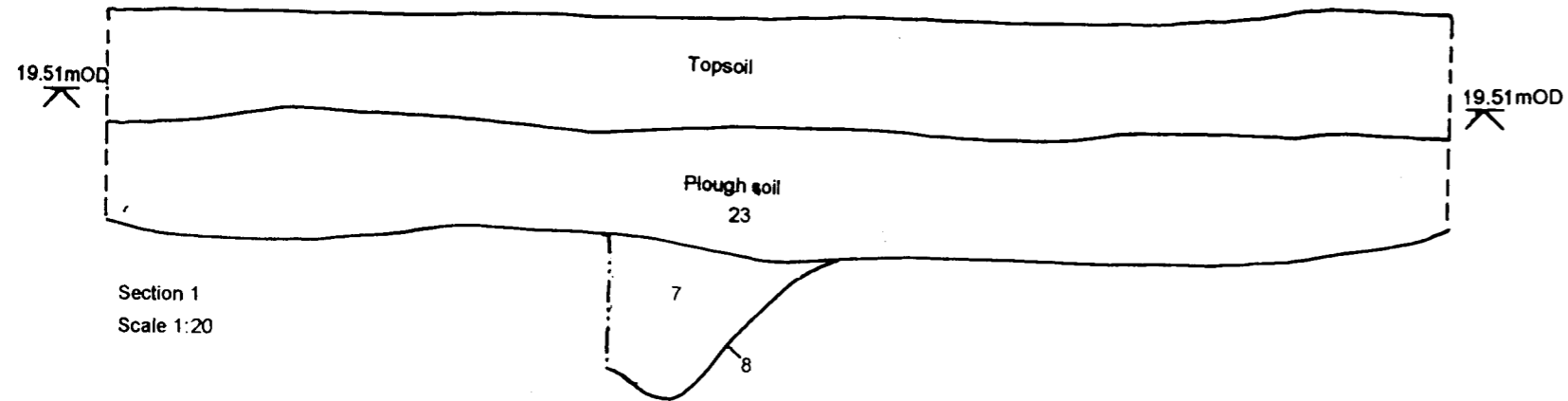
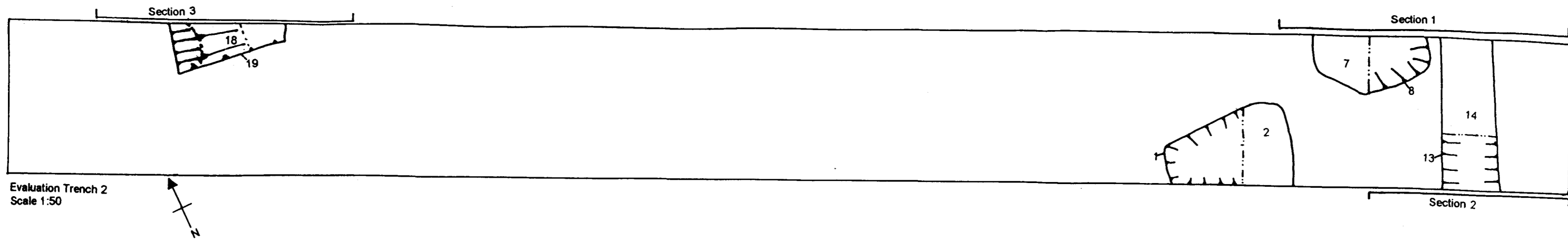



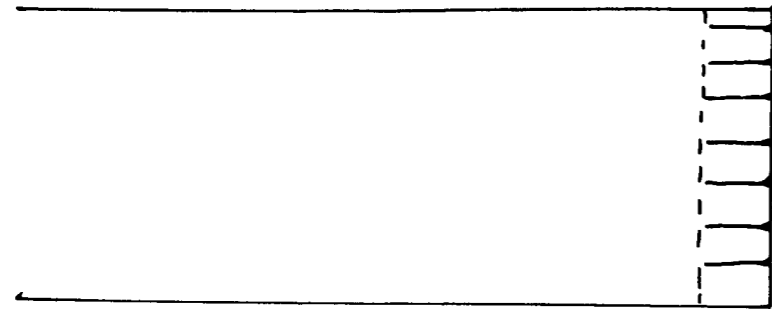
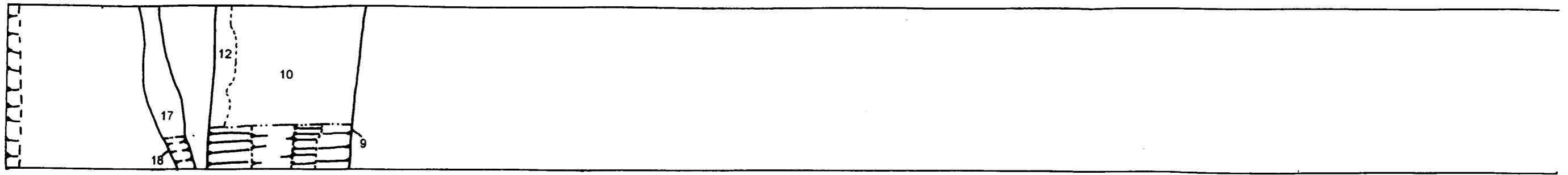

Evaluation Trench 4  
Scale 1:50

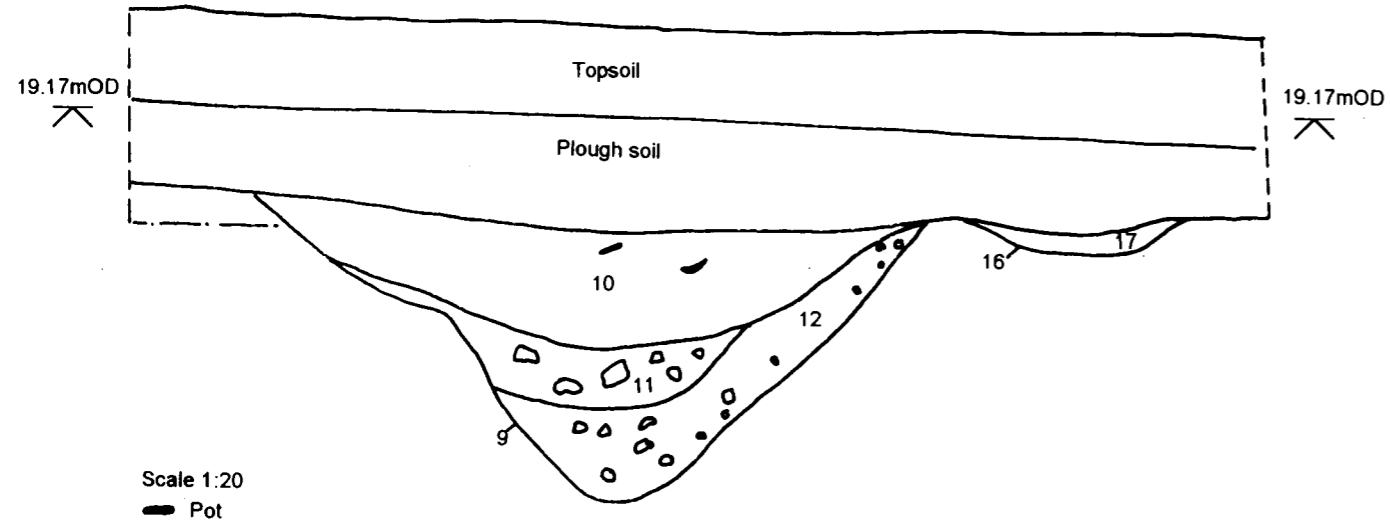

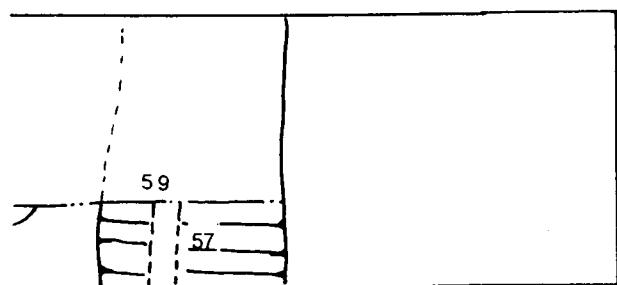
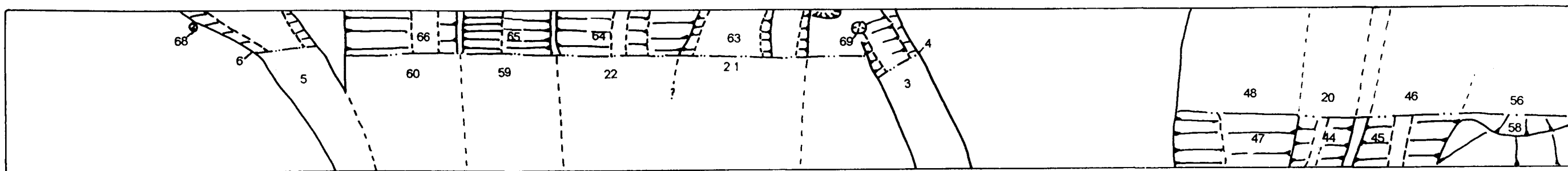

Scale 1:50  
Evaluation Trench 5





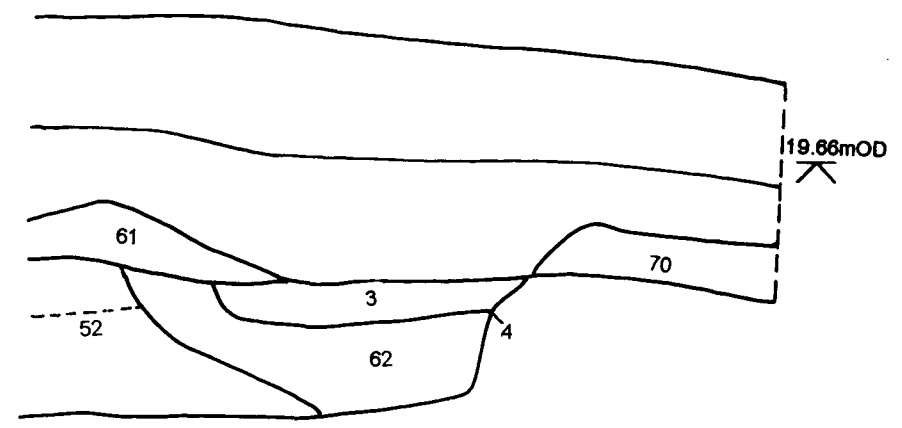
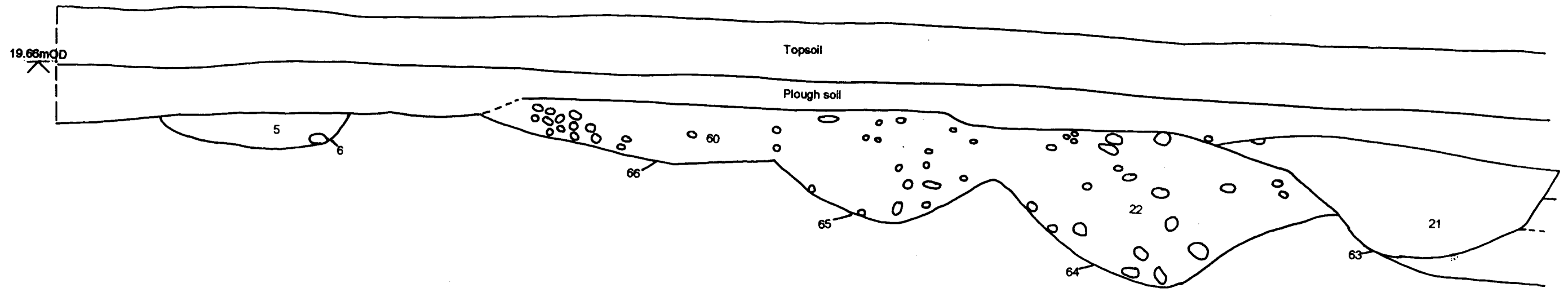

South facing  
Scale 1:20

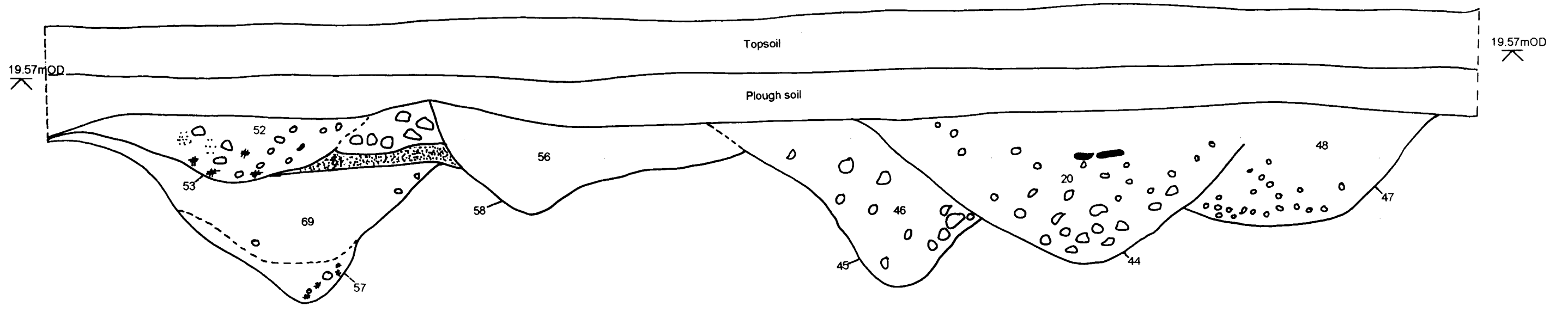

North facing  
Scale 1:20

- Stone
- Pot
- \* Charcoal

Figure 5

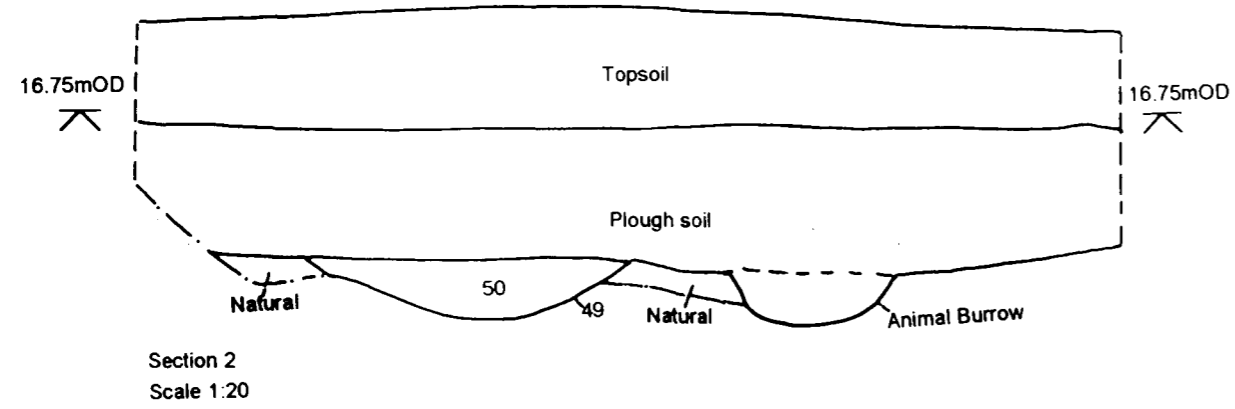
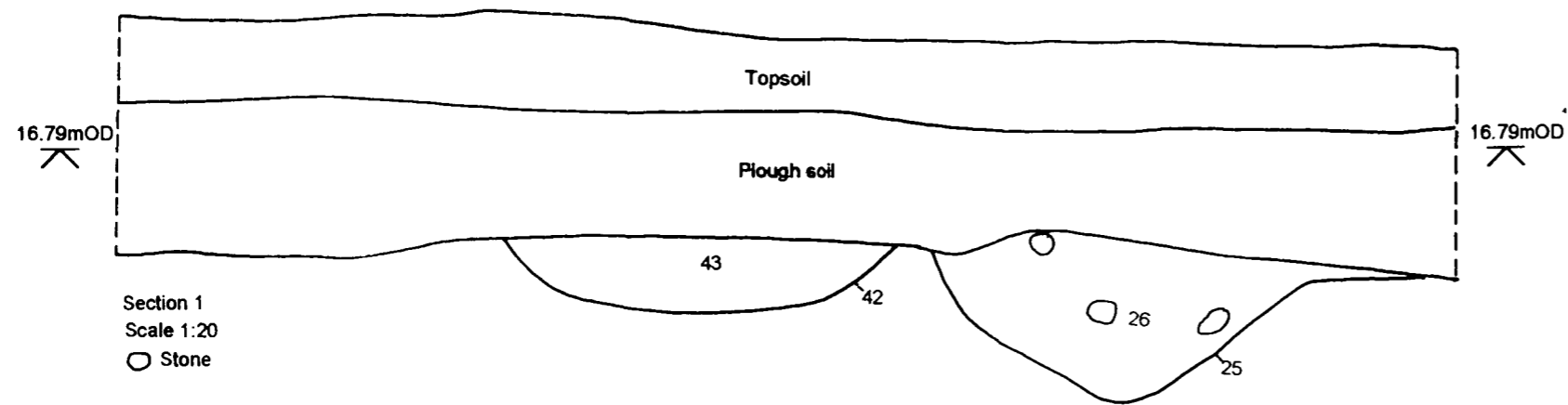
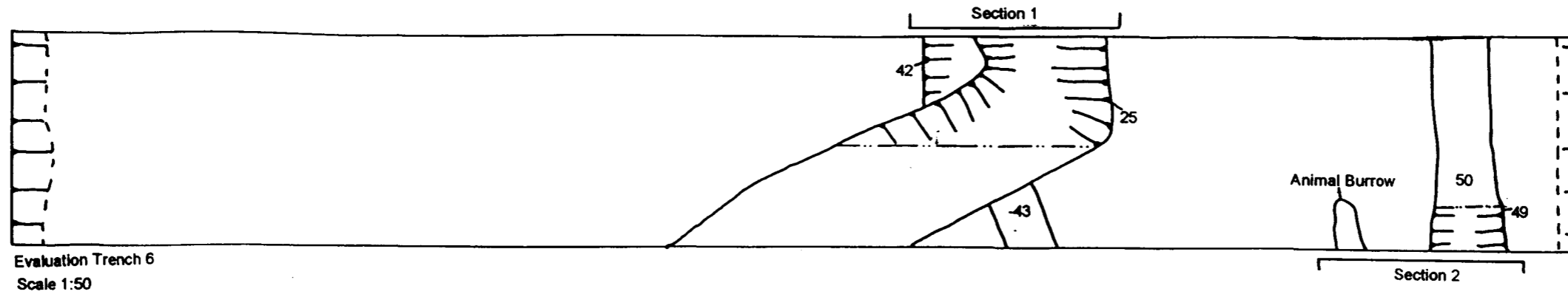
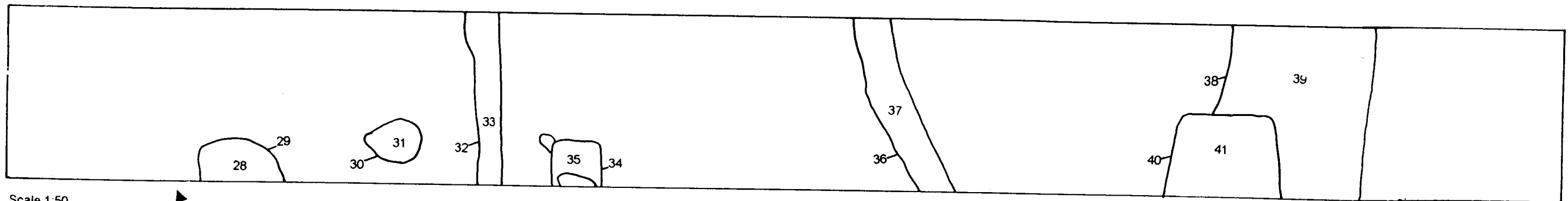

Figure 6





Scale 1:50  
Evaluation Trench 7



**TOTTINGTON FARM,  
AYLESFORD, KENT**

**Report on Archaeogeophysical Survey  
1998**

**Report by:**

**A. Bartlett**

**Geophysical Consultant**

**The Clark Laboratory  
Museum of London Archaeology Service  
87 Queen Victoria Street  
London EC4V 4AB  
0171 410 2200**

**for:**

**Hall Aggregates**



## Tottington Farm, Aylesford, Maidstone, Kent

### Archaeogeophysical Survey 1998

#### Introduction

This survey was carried out to test for evidence of archaeological features or remains in a field north of the gravel quarry entered from Rochester Road, Aylesford, Kent. The survey was commissioned from the Museum of London Archaeology Service by Hall Aggregates, in consultation with the Kent County Archaeologist.

The survey covers a triangular area centred at approximately TQ 73205945, as seen on the plans enclosed. This area contains a cropmark enclosure, and a Belgic cremation cemetery is recorded nearby to the south. Earthwork enclosures and associated settlement activity should usually respond to geophysical surveying techniques, although graves or cremations are unlikely to be directly detectable. Fieldwork for the survey was carried out in August – September 1998 following removal of the crop.

#### Survey Procedure

A magnetometer survey, with readings recorded at 0.25m intervals along transects 1m apart using Geoscan fluxgate magnetometers, was carried out across the area as indicated by the grey scale plot on plan 1. The survey was located by reference to a baseline, which is indicated by red crosses at 30m intervals on the plans, and which was measured to the field boundaries.

The survey results are displayed as standard graphical and grey scale plots at 1:1000 scale on plans 1 and 2. The graphical plot (plan 2) represents the initial data after preliminary correction for irregularities in line spacing caused by variations in the instrument zero setting. Additional 2D low pass filtering has been applied to the grey scale plot to reduce background noise levels and emphasise the broader features which may be archaeologically significant.

Outlines indicating the location of selected magnetic anomalies are shown superimposed on the survey plot on plan 2. The same interpretation is reproduced at 1:1250 scale to provide a summary of the findings on plan 4.

The magnetometer survey was supplemented by a magnetic susceptibility survey with readings taken at 10m intervals using a Bartington MS2 meter and field sensor coil. Magnetic susceptibility surveying detects areas in which burnt material and other debris associated with past settlement or industrial activities has become dispersed in the topsoil, and so can be used to provide a broad indication of occupied or disturbed

areas. The susceptibility readings are represented on plan 3 as shaded squares of density proportional to the readings.

## **Results**

### Magnetometer Survey

The survey plots show a considerable degree of magnetic activity, not all of which is necessarily of archaeological origin, although linear features which clearly correspond to the ditches of the cropmark enclosure have been detected.

The magnetic anomalies as outlined in red on plans 2 and 4 are those which in terms of their plan or profile appear most likely to represent potential archaeological features. Comparison with the cropmarks, which have been traced from a plan supplied by Kent County Council and are indicated schematically on plan 4, confirms that most of the previously recorded features have been detected, although the enclosure is rather larger than is indicated on the cropmark plan. The magnetic anomalies are comparatively weak (the outlines as shown on plans 2 and 4 are drawn at a contour level of 0.5nT), but the north-south enclosure ditches in particular are quite distinct. The east-west ditches, which lie parallel to the survey transects, are in some cases less clearly resolved. An additional enclosure, which was not recorded in the cropmark plan, has been detected at the north west corner of the survey.

It is not fully clear from the survey whether any concentrations of other smaller archaeological features of a kind which could indicate settlement remains associated with the enclosures are present, but there is some evidence that this may be the case. The site unfortunately shows a slightly greater than usual level of background noise, and small magnetic anomalies are visible throughout the survey. Only a few of these are narrow peaks caused by buried iron, and many may represent naturally magnetic stones in the underlying gravel. Small man-made features are not easily identifiable against this background, but a number of selected anomalies and areas of increased strength of response which may indicate silted pits or other features of archaeological origin are outlined on plans 2 and 4 in green. This interpretation may well be incomplete, but it is also possible that some of the disturbances as outlined may be of natural or geological origin.

### Magnetic Susceptibility Survey

The magnetic susceptibility plot (plan 3) shows enhanced values in some parts of the site, and there appears to be a relationship between these areas and the magnetometer findings. A contour enclosing susceptibility values exceeding 50 SI is shown for comparison with the magnetometer results on plan 4. This takes in much of the interior of the main cropmark enclosure, together with some of the magnetic anomalies of possible archaeological interest which are outlined in green, as discussed above.



## Conclusions

The survey has confirmed that the previously recorded cropmark enclosure survives, and is slightly larger than indicated on the available plan. A second smaller enclosure was also detected to the north west of the main enclosure.

The geology of the site creates a slightly disturbed magnetic background which causes difficulties for the detailed interpretation of smaller magnetic anomalies, and so it is not entirely clear whether any concentrations of well-preserved settlement remains are likely to be present. The correspondence between the magnetometer and susceptibility findings would be consistent with the presence of such features, but further investigation would be needed to confirm this possibility.

### Surveyed by:

A. Bartlett BSc MPhil

Geophysical Consultant

The Clark Laboratory  
Museum of London Archaeology Service  
87 Queen Victoria Street  
London EC4V 4AB

0171 410 2200

A. Gilbert BA assisted with this project.

**Date of report:** 15 September 1998

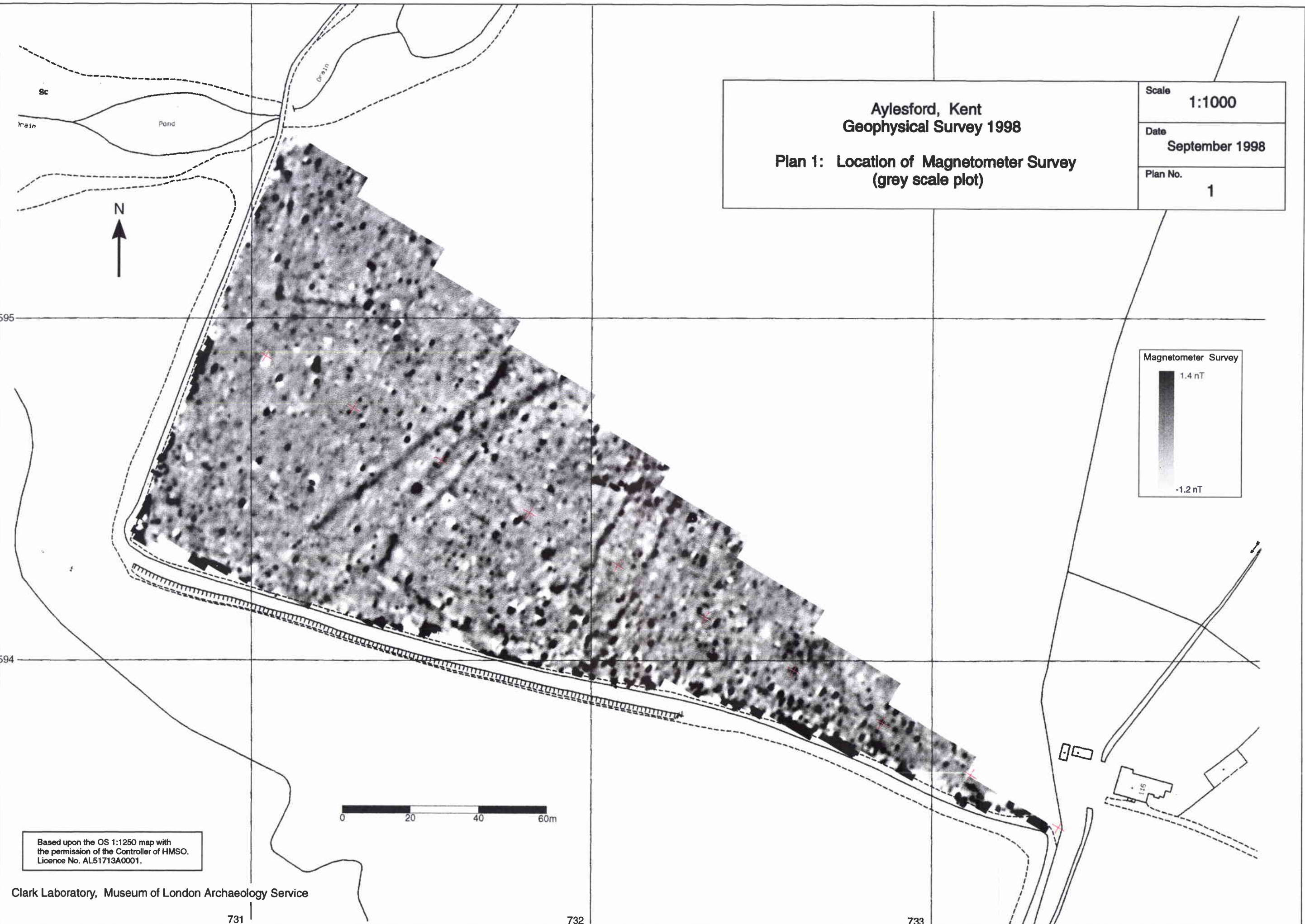

Aylesford, Kent  
Geophysical Survey 1998  
Plan 1: Location of Magnetometer Survey  
(grey scale plot)

Scale	1:1000
Date	September 1998
Plan No.	1

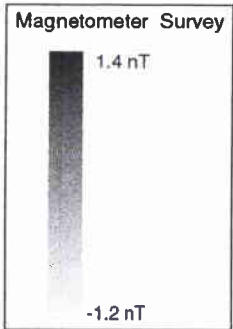

Based upon the OS 1:1250 map with the permission of the Controller of HMSO. Licence No. AL51713A0001.

Clark Laboratory, Museum of London Archaeology Service

731

732



733

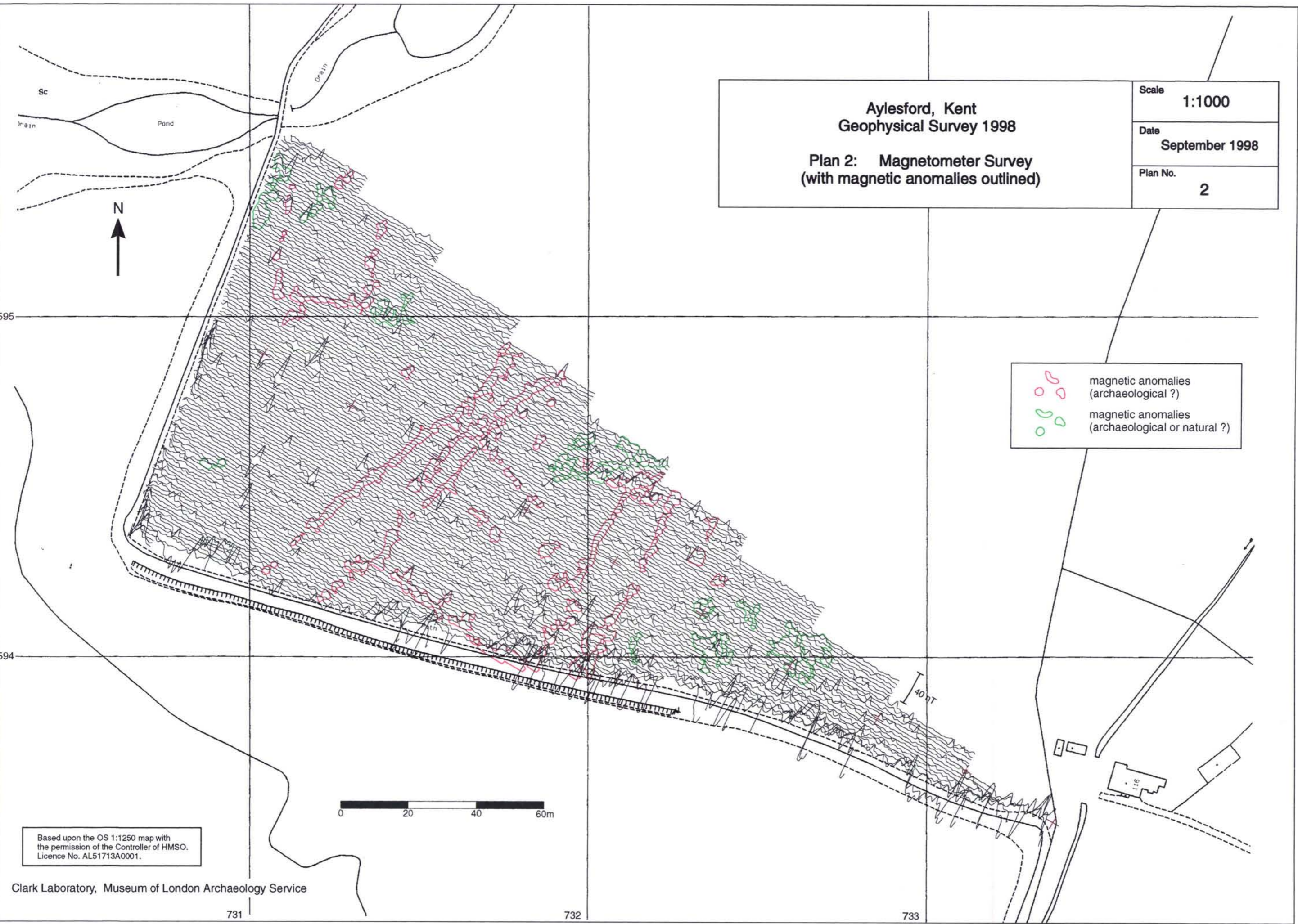



**Aylesford, Kent**  
**Geophysical Survey 1998**  
**Plan 2: Magnetometer Survey**  
**(with magnetic anomalies outlined)**

Scale	1:1000
Date	September 1998
Plan No.	2

 magnetic anomalies (archaeological ?)  
 magnetic anomalies (archaeological or natural ?)

Based upon the OS 1:1250 map with the permission of the Controller of HMSO. Licence No. AL51713A0001.

Clark Laboratory, Museum of London Archaeology Service

731

732

733



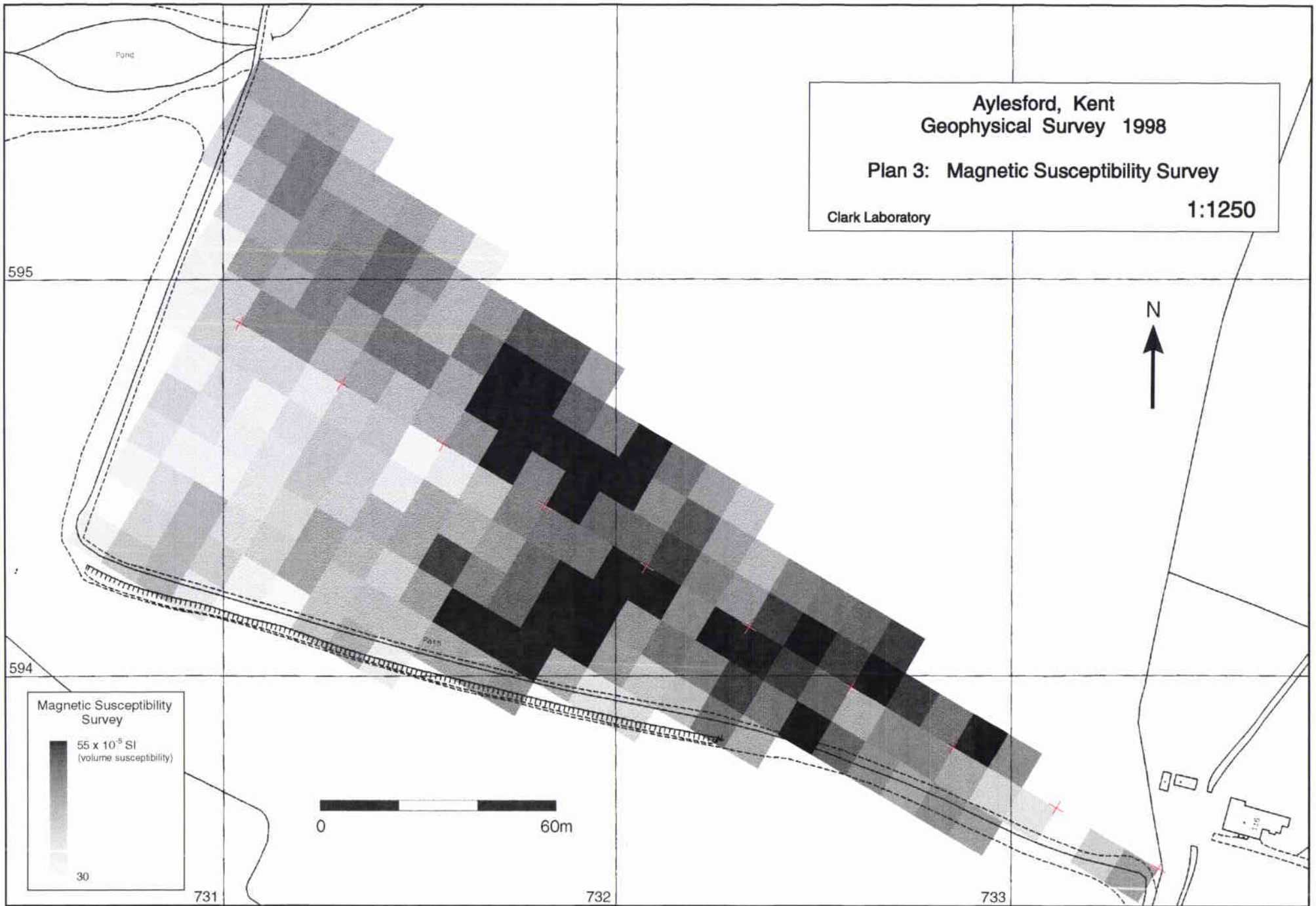



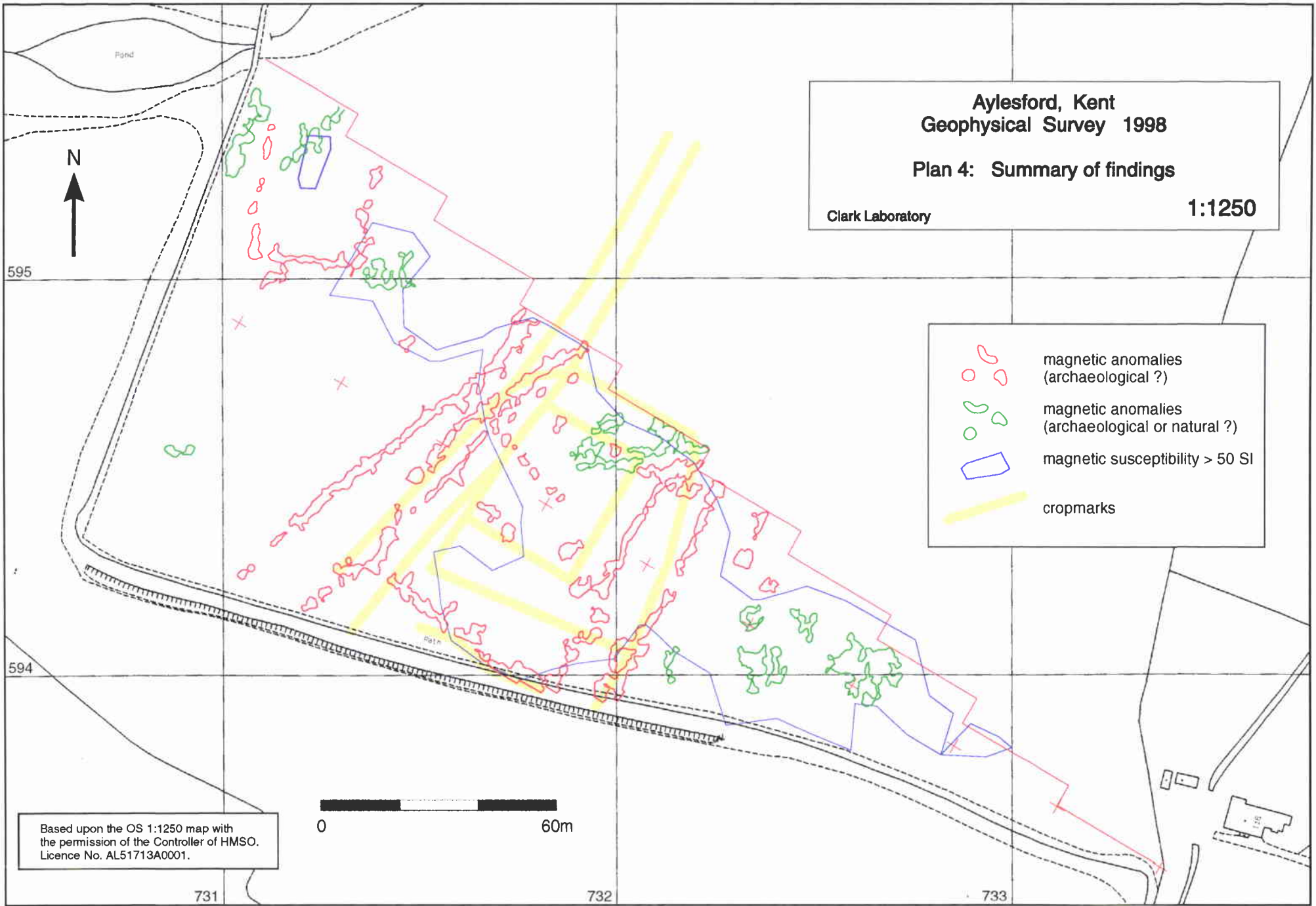





**Aylesford, Kent**  
**Geophysical Survey 1998**  
**Plan 4: Summary of findings**  
Clark Laboratory 1:1250

-  magnetic anomalies (archaeological ?)
-  magnetic anomalies (archaeological or natural ?)
-  magnetic susceptibility > 50 SI
-  cropmarks

Based upon the OS 1:1250 map with the permission of the Controller of HMSO. Licence No. AL51713A0001.

0  60m

731

732

733

595

594